

RENEWAL PARTS PUB FOR NEMA SIZE 8 NON-REVERSING AND REVERSING CONTACTORS AND STARTERS

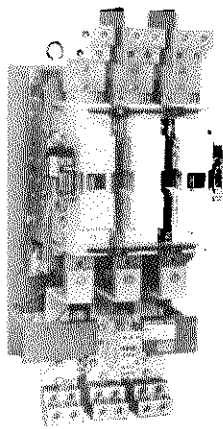

Typical Size 8 Starter

INTRODUCTION

This publication is designed to simplify inspection and maintenance through the use of photographs and detail views for easy identification of parts. Illustrated steps on assembly and disassembly are shown. This information should be read carefully.

DESCRIPTION

This publication covers 3 Pole, 3 Phase Non-Reversing and Reversing Contactors and Starters with ratings as shown on the nameplate of the equipment.

CARE

These contactors/starters require no mechanical maintenance. If maintenance is needed, please note that these devices use metric hardware. All power contacts should be renewed at the same time before the contact tip material has worn away. Refer to Publication 14183 for helpful information on inspecting and determining when to replace the contacts. When renewing contacts, check all terminal screws to insure they are tight and secure. During routine electrical maintenance, the arc chutes are to be removed to inspect the main contacts for wear and to check the fuse links (located below the line terminals) to see that they are not open. Fuse link and main contact replacement are covered in this publication. Please note Figure 9 exploded view drawing for service or repair.

DANGER
Hazard of Burn or Electrical Shock

Turn OFF power supplying this equipment before working inside.

All work on this contactor should be done with the main circuit disconnect device open. There is danger of electrocution and/or severe burns. Make certain that power is off. Also, disconnect power from any other external circuits.

ARC CHUTE REMOVAL

1. Disconnect all power to the contactor/starter.
2. Loosen the 4 screws attached to the arc chute hold-downs far enough to rotate them 90°. See Figure 1.
3. Remove the 3 arc chutes.
4. To reinstall the arc chutes, reverse the above.

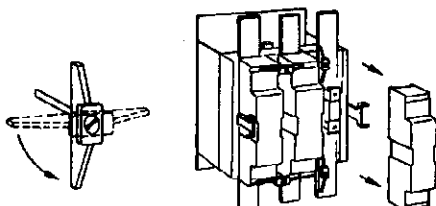

Figure 1 - Arc Chute Removal

MAIN COIL RENEWAL

Caution - If the device has been in service, many parts may still be thermally hot.

1. Disconnect all power to the contactor/starter.
2. Remove arc chutes.
3. Loosen the 2 screws that secure each coil.
4. Push on pole two movable contact assembly until the main contacts touch. **Caution** - If device was in service, the contacts will be very hot.
5. When main contacts touch, pull upward on the lever located directly behind the L2 terminal to lock open the magnet. Then release the pressure on the movable contacts until they stop at their full open position. See Figure 2.
6. Grasp the coil by its handle and pull straight forward to remove.
7. Slide in new coils and tighten the screws to secure in place.
8. Push firmly on pole two movable contact assembly until the main contacts touch. The magnet coil will then lock into place. Release the movable contacts.
9. Reinstall the arc chutes.



Figure 2 - Coil Removal

MAIN COILS

Control Voltage		Main Coil Part No. (1 Required)
Volts	Hertz	
120	50/60	9-2654
240	50/60	9-2654-2
480	50/60	9-2654-3
600	50/60	9-2654-4
380	50/60	9-2654-5
208	50/60	9-2654-6
415	50/60	9-2654-7
110	50/60	9-2654-8
220	50/60	9-2654-9
550	50/60	9-2654-10
440	50/60	9-2654-11

FEEDER GROUP

This is the panel assembly located below the contactor load terminals. It supplies the main contactor coils with DC control voltage. See publication supplied with contactor/starter for wiring diagram.

FEEDER GROUP RENEWAL

1. Disconnect all power to the contactor/starter.
2. Disconnect the 6 wires going to the terminal block.
3. Remove the two contactor mounting screws. Remove the two allen screws using a 6mm allen wrench. Remove feeder group from starter.
4. Reverse the above to install new feeder group

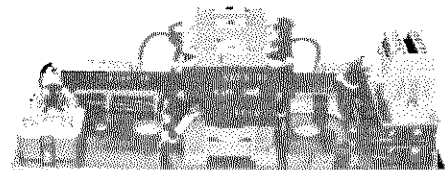

Figure 3 - Feeder Group

Feeder Group Renewal Parts - See Figure 3

Control Voltage		Feeder Group (Complete)
Volts	Hertz	
120V	50/60	9-2664
240V	50/60	9-2664-2
480V	50/60	9-2664-3
600V	50/60	9-2664-4
380V	50/60	9-2664-5
208V	50/60	9-2664-6
415V	50/60	9-2664-7
110V	50/60	9-2664-8
220V	50/60	9-2664-9
550V	50/60	9-2664-10
440V	50/60	9-2664-11

RENEWAL OF DAMPER CONTACTS

1. Disconnect all power to the contactor/starter.
2. Remove the arc chutes and main coils as previously described.
3. Remove the main contacts as previously described.
4. Remove contact guide bracket, return spring, and movable contact by removing the 2 mounting screws. See Figure 7. Tilt the guide bracket as shown to remove.
5. Remove the stationary contacts using a 10mm wrench.
6. Install new stationary contacts and lockwashers.
7. Install the new contact guide bracket, return spring, and movable contact.
8. Reinstall the main contacts, the coils, and the arc chutes.

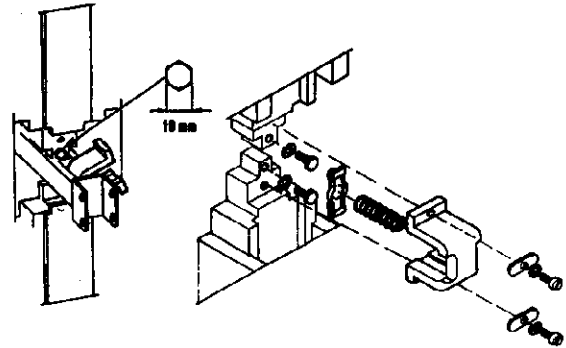

Figure 7 - Damper Contact Renewal

FUSE LINK RENEWAL

1. Disconnect all power to the contactor/starter.
2. Remove arc chutes.
3. Remove mounting hardware. See Figure 4.
4. Remove fuse link. Reinstall new fuse link based on the line voltage. See table in Figure 4.

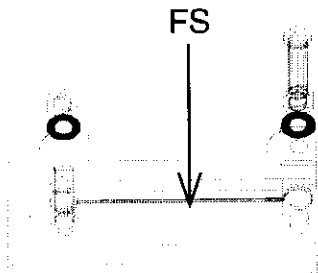

Figure 4 - Fuse Link

Line Voltage	Fs Color
208/240	Green
380	Black
480/600	Red

See Renewal Parts Information for Replacement Fuse Links

RENEWAL OF THE MAGNET FRAME ASSEMBLY

This consists of 2 "U" shaped frames located under the line and load sides. Both frames are to be replaced using the following procedure. See Figure 8.

1. Disconnect all power to the starter/contacter.
2. Remove the locking ring, Item 1, from one end of the support shaft, Item 2.
3. Slide the support shaft outward until it clears the magnet frame. Be careful not to lose the nylon spacers. Support the magnet so it does not fall.
4. Remove the magnet.
5. Reverse Steps 2 and 3 to reinstall the new magnet frame. **NOTE** - It may be necessary to lightly lubricate the shaft with "MolyCoat" grease or equivalent before reassembly.

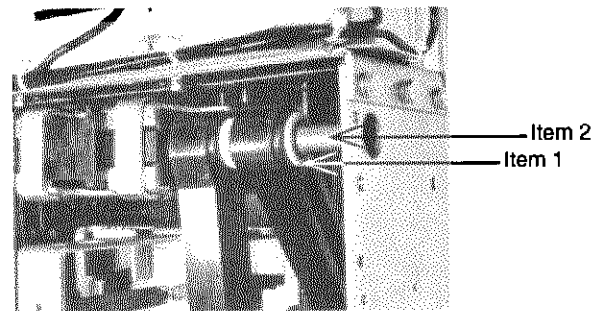
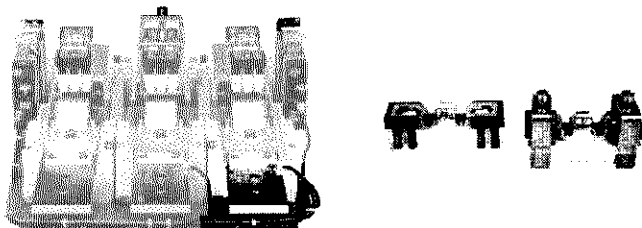

Figure 8 - Magnet Renewal

MAIN CONTACT RENEWAL

1. Disconnect all power to the contactor.
2. Remove arc chutes.
3. Install contact removal tools onto movable contact assembly. See Fig. 5.
4. Compress the contact springs about 1/16" by turning down screw until the locking pins become loose.
5. Remove locking pins by sliding them to the right or left.
6. Remove movable contact assembly and tools.
7. Remove stationary contacts by removing the 3 allen screws. Use a 6mm allen wrench.
8. Install new stationary contacts and screws.
9. Assemble movable contacts, springs, and spring retainers. Hold them together using the contact tools. See Figure 6.
10. Place the movable contact assembly into the drive bracket. Make sure that the pin fits into the center movable contact.
11. Compress the contact springs about 1/2" using the assembly tools until you can slide the locking pins into position.
12. Slide locking pins into place.
13. Remove contact tools.
14. Install arc chutes.

NOTE: The damper contacts should be replaced when the main contacts are renewed. See "Renewal of Damper Contacts" and Figure 7.



Figures 5 and 6 - Main Contact Renewal

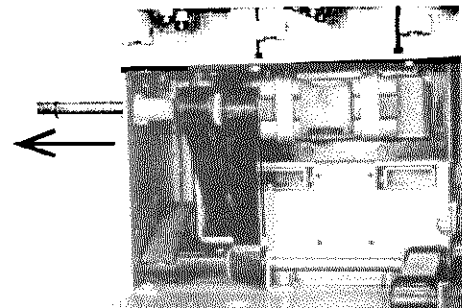

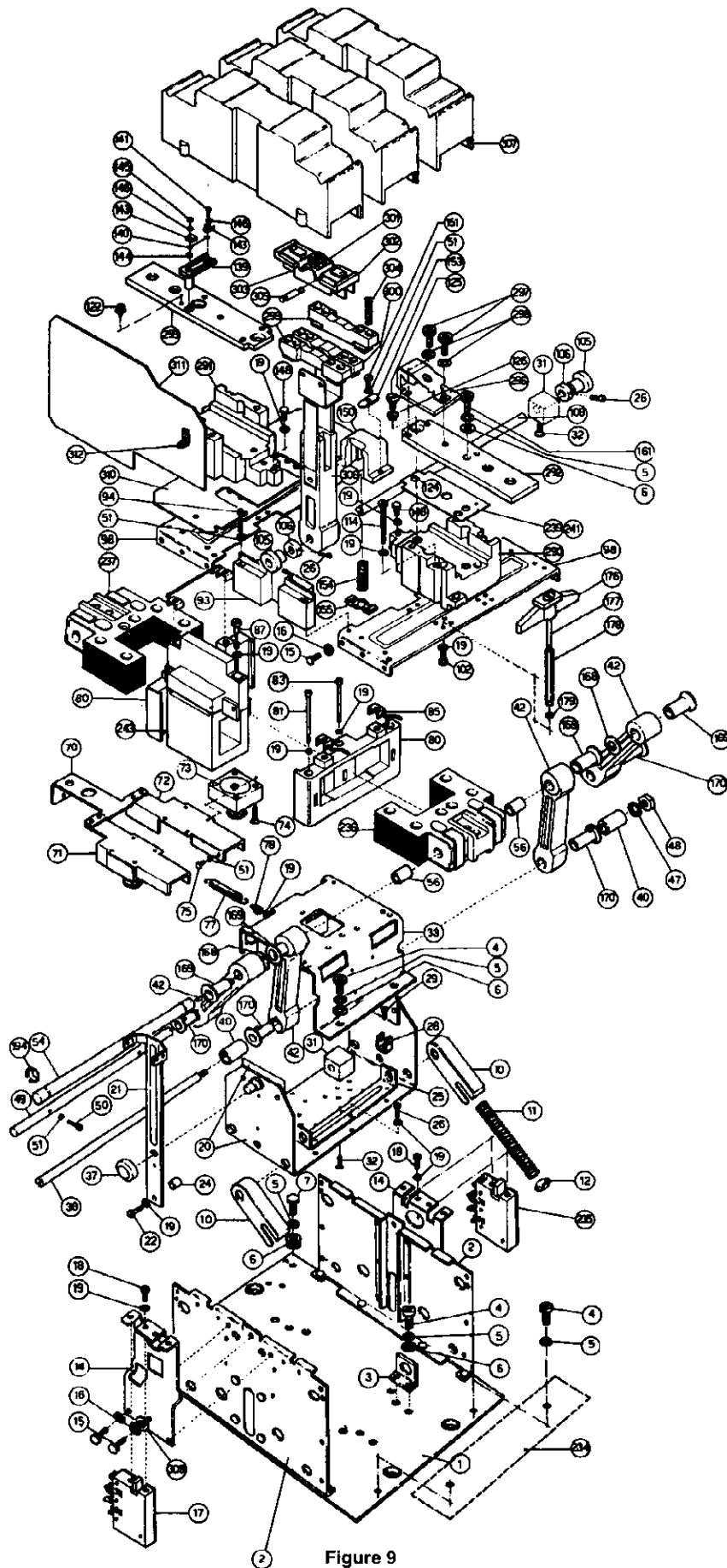

Figure 9

ITEM NUMBER	DESCRIPTION	PART NUMBER	QUANTITY				ITEM NUMBER	DESCRIPTION	PART NUMBER	QUANTITY			
			CN15	AN16	CN55	AN56				CN15	AN16	CN55	AN56
1	Mounting Plate Assembly						154	Contact Spring Damper Circuit	See Item 328	3	3	6	6
	Base Plate		1	1	2	2	155	Movable Contact					
2	Side Plate		2	2	4	4		Damper Circuit	See Item 328	3	3	6	6
3	Bracket		4	4	8	8	161	M8 x 22 Screw		3	3	6	6
4	M8 x 16 Allen Screw		14	14	28	28	168	Spacer		4	4	8	8
5	Helical Lockwasher (M8)		18	18	36	36	169	14mm Rod Bushing		8	8	16	16
6	Flat Washer (M8)		17	17	34	34	170	12mm Rod Bushing		8	8	16	16
7	M8 x 16 Hex Screw (Ground)		1	1	2	2	176	Arc Chute Hold-Down	99-2164	4	4	8	8
10	Return Spring Guide		4	4	8	8	177	M6 x 100 Screw	See Item 176	4	4	8	8
11	Return Spring		4	4	8	8	178	Threaded Column	See Item 176	4	4	8	8
12	Return Spring Retainer		4	4	8	8	179	Internal Tooth Lockwasher (M5)	See Item 176	4	4	8	8
14	Auxiliary Mounting Bracket		2	2	4	4	194	Clip Ring		4	4	8	8
15	M6 x 10 Screw		18	18	36	36	234	Feeder Group	See Table, P. 2				
16	Helical Lockwasher (M6)		18	18	36	36	235	Auxiliary Contact DC	10-5883	1	1	2	2
17	Auxiliary Contact (NO/NC)	C320KA5	1	1	2	2	236	Magnet Frame, Lower					
18	M5 x 8 Shoulder Screw		4	4	8	8		(incl Items 56 & 237)	17-17719-3	1	1	2	2
19	Helical Lockwasher (M5)		57	57	114	114	237	Magnet Frame, Upper	See Item 236				
20	Drive Frame Assembly		1	1	2	2	239	1mm Thick Plate		6	6	12	12
21	Aux Contact Drive Bracket		2	2	4	4	241	0.5mm Thick Plate		6	6	12	12
22	M5 x 20 Screw		4	4	8	8	243	Main Coil (incl Item 87)	See Table, P.	1*	1*	2*	2*
24	Spacer		4	4	8	8	290	Lower Terminal Block		3	3	6	6
25	Lower Shaft Support Bracket		2	2	4	4	291	Upper Terminal Block		3	3	6	6
26	M5 x 10		8	8	16	16	292	Lower Terminal Plate		3	3	6	6
28	Pivot Bracket		4	4	8	8	293	Upper Terminal Plate		3	3	6	6
29	M5 x 10 Screw		4	4	8	8	296	Stationary Contact	See Item 328	6	6	12	12
31	Pivot Support Block		2	2	4	4	297	M8 x 16 Screw	See Item 328	18	18	36	36
32	M6 x 10 Screw		4	4	8	8	298	Helical Lockwasher	See Item 328	18	18	36	36
33	Coil Support Frame		1	1	2	2	299	Outside Movable Contact	See Item 328	6	6	12	12
37	Roller		2	2	4	4	300	Center Movable Contact	See Item 328	3	3	6	6
38	Threaded Rod		2	2	4	4	301	Retainer Bracket	See Item 328	3	3	6	6
40	Spacer		4	4	8	8	302	Contact Spring Retainer	See Item 328	6	6	12	12
42	Pivot Arm		8	8	16	16	303	Contact Barrier	See Item 328	6	6	12	12
47	Helical Lockwasher (M10)		2	2	4	4	304	Contact Spring	See Item 328	36	36	72	72
48	Hex Nut (M10)		2	2	4	4	305	Locking Pin	See Item 328	6	6	12	12
49	Rod		2	2	4	4	306	Movable Contact Drive Assy		3	3	6	6
50	M4 x 18 Screw		4	4	8	8	307	Arc Chute	61-842-2	3	3	6	6
51	Helical Lockwasher (M4)		16	16	32	32	309	Flat Washer (M6)		2	2	4	4
54	Magnet Frame Support Rod		2	2	4	4	310	Frame Barrier	73-2788	2	2	4	4
56	Magnet Frame Bushing		4	4	8	8	312	Phase Barrier (incl Item 312)	73-2789	2	2	4	4
70	Coil Release Bracket Assy		1	1	2	2	313	Fuse Block Assembly	C320FBR	2	2	2	2
72							314	6-32 x .750" Sems Screw	11-3417	4	4	4	4
73	Shock Absorber		2	2	4	4	315	1/2-13 x 1.00" Hex Screw	911-5888Z	4	4	8	8
74	M5 x 25 Screw		8	8	16	16	316	1/2 Helical Lockwasher	916-199	4	4	8	8
75	M4 x 8 Screw		2	2	4	4	317	3/8-16 x 1.75" Hex Screw	911-5654Z	12	9	12	3
77	Return Spring		1	1	2	2	318	3/8 Helical Lockwasher	916-231	12	18	15	15
78	Spring Pivot		1	1	2	2	319	3/8-16 Hex Nut	915-1004Z	12	9	15	15
80	Magnet Support Frame		2	2	4	4	320	3/8-16 x 1.50" Hex Screw	911-5652Z	-	6	-	12
81	M5 x 75 Screw		4	4	8	8	321	3/8 Washer	916-882Z	-	3	-	3
83	M5 x 60 Screw		2	2	4	4	322	Current Transformer	42-3598-3	-	1	-	1
85	Coil Connectors		4	4	8	8	323	10-32 x .562 Sems Screw	11-681	-	4	-	4
93	Side Insulating Block		2	2	4	4	324	Insulator	56-3258-4	-	3	-	3
94	M4 x 30 Screw		4	4	8	8	325	3/8-16 x .625" Hex Screw	911-5645Z	-	3	-	3
98	Terminal Block Platform		2	2	4	4	326	Overload Relay	C306DN3	-	1	-	1
102	M5 x 12 Screw		4	4	8	8	327	Terminal Base Adapter	10-6380-2	-	1	-	1
105	Roller		2	2	4	4	328	8-32 x .625" Sems Screw	11-697	-	2	-	2
106	Locking Bushing		2	2	4	4	329	Lug	80-4181	6	6	6	6
108	Connecting Rod		1	1	2	2	330	Top Plate	81-15983	-	1	-	1
114	M5 x 60 Screw		24	24	48	48	331	Side Plate	47-28267	-	2	-	2
122	M3 x 5 Screw		3	3	6	6	332	1/4-20 x .500" Sems Screw	11-1108	-	9	-	9
125	8 x 16 Screw		9	9	18	18		(also used to mount side plates, top plate, and current transformer, Items 322, 330, and 331)					
126	Countersunk Ext Tooth Lockwasher (M8)		9	9	18	18							
139	Fuseholder		3	3	6	6	333	1/4 Washer (not shown) (used to mount current transformer, Item 322)	916-641Z	-	4	-	4
140	Fuse Wire Kit	44-2078	1	1	2	2							
141	M4 x 12 Screw		3	3	6	6							
143	Anti-Rotation Plate		6	6	12	12	334	Bus Bar	19-2922	-	3	-	3
144	M4 x 2 Hex Nut		3	3	6	6	335	Contact Kit (not shown) (incl Items 148-155 & 296-305)	6-571	1			
145	M4 x 4 Hex Nut		3	3	6	6	336	Main Terminal Mounting Kit (not shown) (IEC devices only)	99-2183				
146	Spring Washer		6	6	12	12							
148	Stationary Contact												
	Damper Circuit	See Item 328	6	6	12	12							
150	Guide Bracket	See Item 328	3	3	6	6							
151	M4 x 16 Screw	See Item 328	6	6	12	12							
153	Clamping Plate	See Item 328	6	6	12	12							

* 1 main coil set = 2 separate coils

NOTE: Only the parts listed with a part number are available for replacement. All other parts are shown and described for identification only.

RENEWAL OF CURRENT TRANSFORMER

1. Disconnect all power to the starter.
2. Remove all wires from overload relay.
3. Remove the four screws, Item 323 and remove top plate, Item 330.
4. Remove load side lugs, Item 329.
5. Remove bus bar connecting bolts at contactor, Item 320.
6. Remove the two outside bus bars from the current transformer
7. Remove the four current transformer mounting screws, Item 332.
8. Remove current transformer from panel. Remove center bus bar.
9. Mount new current transformer reversing the steps above.

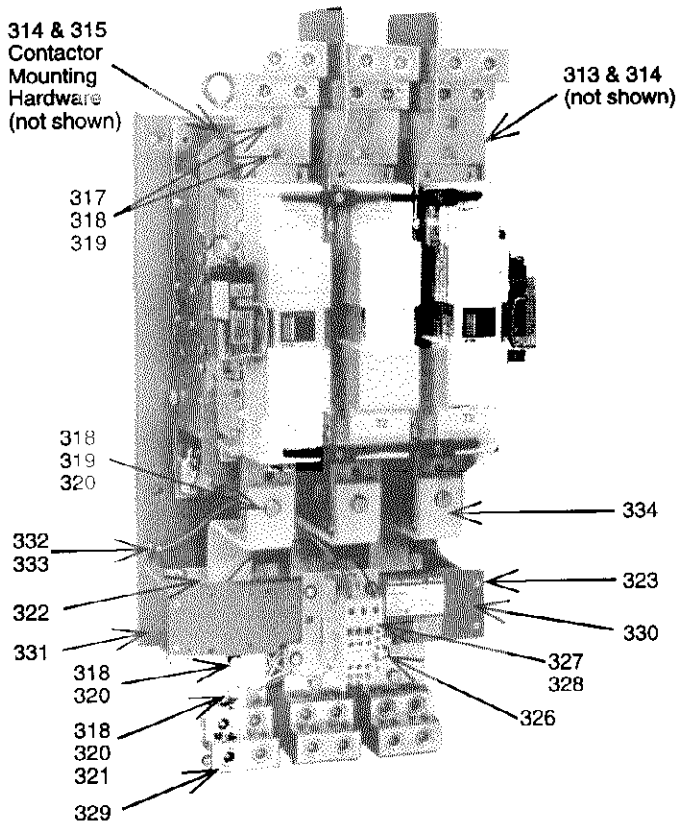

Figure 10

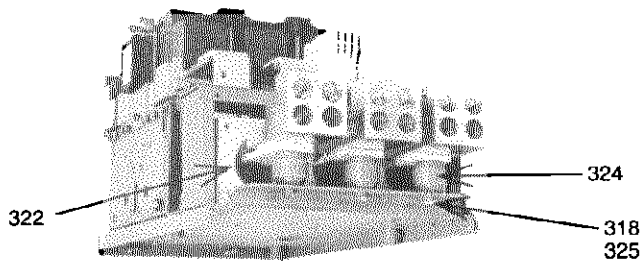

Figure 11

RENEWAL OF BIMETAL OVERLOAD RELAY

This bimetal ambient compensated overload relay is adjustable within the FLA range of the heater pack. Each heater pack is marked with its range of FLA ratings.

Select heater pack (3 required) according to the motor FLA rating and install in overload relay. Rotate FLA adjustment dial to a position corresponding to the motor FLA. Consult overload relay publication supplied with the starter for proper setting and selection. The overload relay is factory set for manual reset operation. If automatic reset is required, turn the reset adjustment dial to "Auto".

FLA ADJUSTMENT DIAL

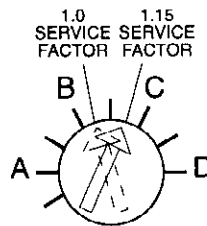

RESET ADJUSTMENT DIAL

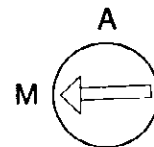

Example of setting for manual reset

The entire overload relay must be replaced if burnout of the heater occurs.

DO NOT DISASSEMBLE THIS RELAY!

AUXILIARY INTERLOCKS

The electrical interlocks are renewable as a complete assembly. They are available in a NO/NC configuration.

Little care is required for the interlocks beyond occasional examination to ensure that parts move freely without interference or binding.

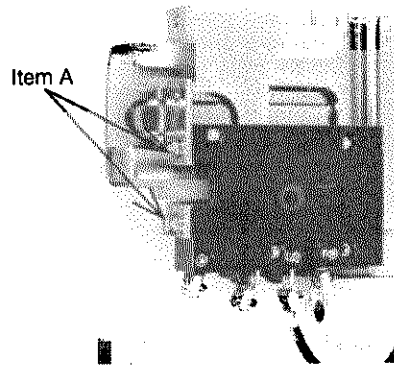

Figure 12

INSTALLATION INSTRUCTIONS

1. Remove screws and lockwashers (Item A) from top of interlock.
2. Line up holes in interlock with desired holes in mounting frame - right or left side of device.
3. Mount the interlock to the frame by installing screws and lockwashers (Item A).
4. Tighten screws to secure interlock to the mounting frame.

FOR A50 AND C50 DEVICES ONLY

MECHANICAL INTERLOCK ADJUSTMENT
HORIZONTAL VERSION
PART NO. 10-5833

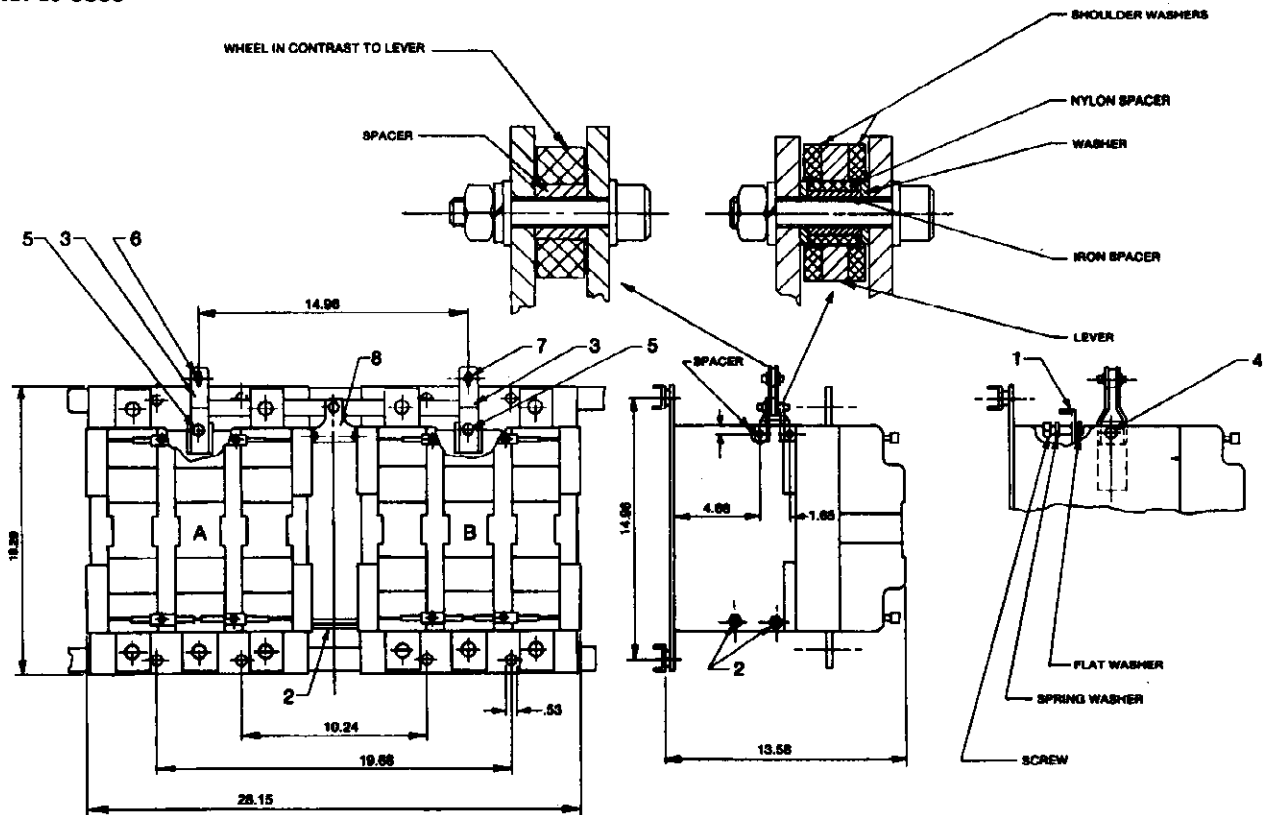

Figure 13

1. Place the two devices A and B in the given position and unite them by means of the two spacers, item 2, and the lever, item 8.
2. Assemble the "U" bolts, item 3, on the magnets, tightening screw 5.
3. Tighten screw 6 in the center of the slot. Loosen screw 7 and energize the A device.
4. Tighten screw 7 so that the wheel is .040 from the lever.
5. Check that the clearance is retained when de-energizing A device and energizing B device.

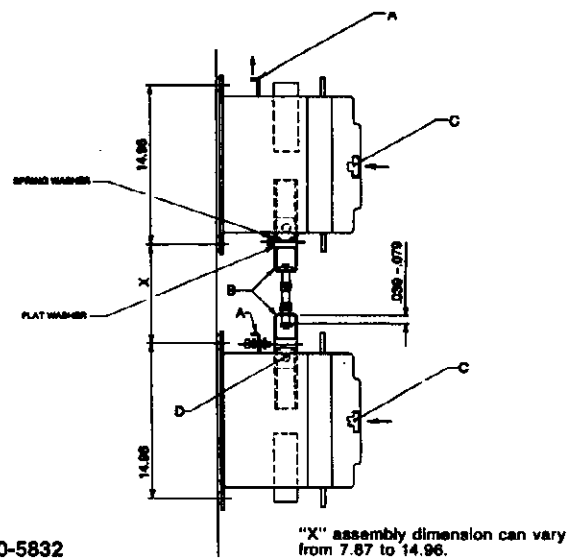

Figure 14

VERTICAL MECHANICAL INTERLOCK - PART NO. 10-5832

1. Pull levers "A" up in order to pull magnets from coils. Mount "B" stirrups onto magnets with M8 x 45 screws.
2. Return magnets to their normal position by pushing on "C" auxiliary contact drive brackets.
3. Adjust device to obtain about .039-.079 clearance as indicated on drawing, upper contactor being energized. Check that clearance is kept when de-energizing upper contactor and energizing lower contactor.