

## RENEWAL PARTS PUB - NEMA SIZE 1 AND 2 AND SIZE 1-3/4 NON-REVERSING AND REVERSING CONTACTORS AND STARTERS

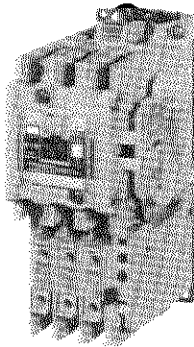

NON-REVERSING STARTER

### INTRODUCTION

This publication is designed to simplify inspection and maintenance through the use of photographs and detail view for easy identification of parts. Illustrated steps on assembly and disassembly are shown. This information should be read carefully.

### DESCRIPTION

This publication covers two and three pole, reversing and non-reversing, NEMA type contactors and starters with ratings as shown on the nameplates.

### CARE

These contactors / starters require no mechanical maintenance. All power contacts should be renewed at the same time before the contact tip material has worn away. Refer to Publication 14183 for helpful information on inspecting and determining when to replace the contacts. When renewing contacts, check all terminal screws to insure that they are tight and secure.

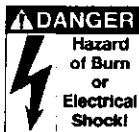

**Disconnect power before any functions are performed on this equipment.**

During routine electrical maintenance, the cover assembly should be removed to inspect the main contacts for wear. Please note exploded view drawing on Page 3 for service or repair.

### MAIN COIL RENEWAL (Figures 1 & 2)

The operating coil is epoxy encapsulated and so constructed to provide long service life. Should the coil require changing, the entire operation can be performed in a few minutes.

**CAUTION:** If the device has been in service, many parts may still be thermally hot.

1. Disconnect coil leads.
2. Remove auxiliary contacts (if used), by pulling side contact tab away from contactor and lifting from side of contactor. See Fig. 1. (It is not necessary to remove auxiliary contact if unwired.)
3. Insert screwdriver beneath the retaining clip of the contactor and pry off from the upper housing. See Fig. 1.
4. **Starters Only** - Loosen the connector screws on the overload relay just enough to disconnect them from the overload relay. Do not remove these screws. (See Item 22 on Page 3.) (A minimum of 8 full revolutions and then turn back 2 revolutions clockwise.)

**Contactors** - Proceed to Step 5.

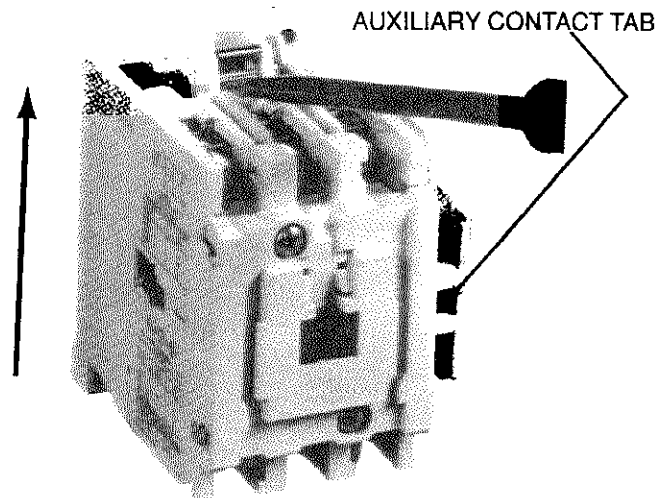

Figure 1

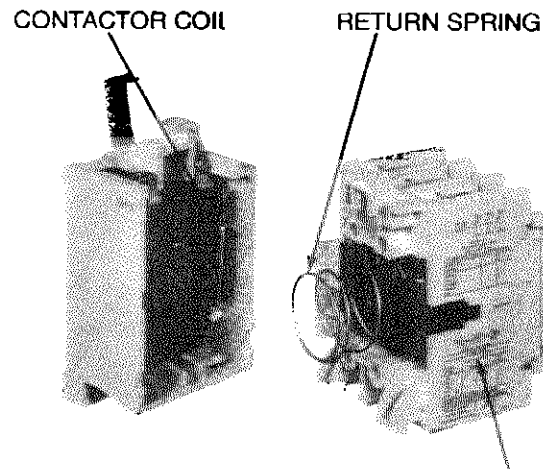

Figure 2 UPPER HOUSING ASSEMBLY

5. Remove upper housing, Item 13, from lower housing, Item 2, by evenly pushing the housing to unhinge the housing while lifting up 1/4 inch in the direction of the arrow. See Fig. 1. (Refer to Page 3 for parts referenced in this step.)
6. Remove old coil and replace with new coil. Reconnect coil leads.
7. Position the return spring onto the armature (see Fig. 2) and install the upper housing to the lower housing (reversing procedure in Step 5).
8. Snap the retaining clip back on the upper housing.
9. **Starters Only** - Make sure the connectors (Item 20) are aligned correctly on the overload relay and tighten the screws. Torque to 9-13 lb-in.
10. Reconnect all leads.
11. Reassemble auxiliary contact if removed in Step 2.
12. Check mechanical movement of contactor.

**MAIN COILS**

Control Voltage		Main Coil Part No. (1 Reqd/Contactor)
Volts	Hertz	
24	50/60	9-2703-16
110/120	50/60	9-2703-1
220/240	50/60	9-2703-2
440/480	50/60	9-2703-3
550/600	50/60	9-2703-4
277	60	9-2703-7
208	60	9-2703-9
48	60	9-2703-11
24	60	9-2703-6
380/415	50	9-2703-8
240	50	9-2703-14
48	50	9-2703-13
32	50	9-2703-10
24	50	9-2703-12

**DC COILS\***

Voltage	Main Coil Part No. (1 Reqd/Contactor)
12	9-2990-1
24	9-2990-2
48	9-2990-3
120	9-2990-4

\*Must be used with C320KGD4 (N.C.) or C320KGD5 (N.O.-N.C.) auxiliary contacts

**MAIN CONTACT RENEWAL** (Figures 3, 4, 5, & 6)

**Disassembly**

1. Disconnect all power to the contactor/starter.
2. Loosen the two gold-colored screws and remove the arc chute assembly from the contactor.
3. **Arc Chutes** - Remove arc chutes from contactor by placing a screwdriver in the small hole of the arc chute and prying up (Fig. 4).
4. **Movable Contacts** - Insert a small screwdriver into the contact springs and pry springs out of contact bar (Fig. 5). Refer to Sketch "A". Rotate contacts as shown and remove from contact bar.
5. **Stationary Contacts** - Remove main wiring. Insert a small screwdriver underneath the stationary contacts and pry contacts out of housing (Fig. 6). **Starters Only** - Remove overload relay from contactor.

**Reassembly**

6. Install new arc chutes into contactor arc chute assembly. Make sure arc chutes are pressed in tightly.
7. Install new stationary contacts into contactor housing, making sure that contacts seat firmly.
8. Install new movable contacts into contact bar. Compress contact springs between thumb and forefinger and insert springs so that springs engage both detents of contact and contact bar.
9. Install arc chute assembly onto contactor and torque gold-colored screws to 15 lb-in.

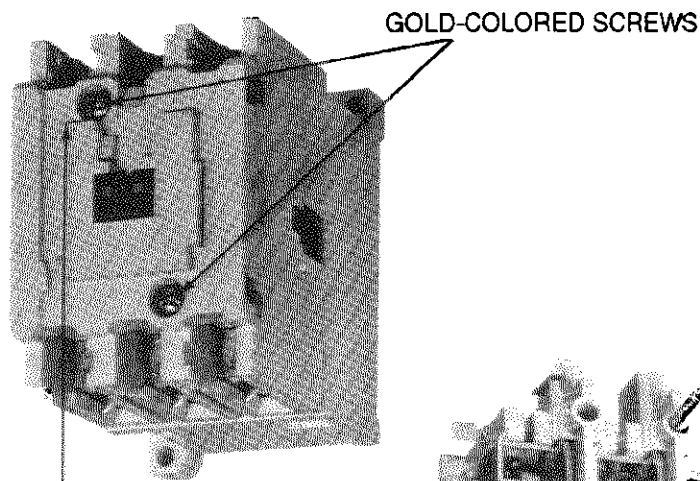

ARC CHUTE ASSEMBLY

Figure 3

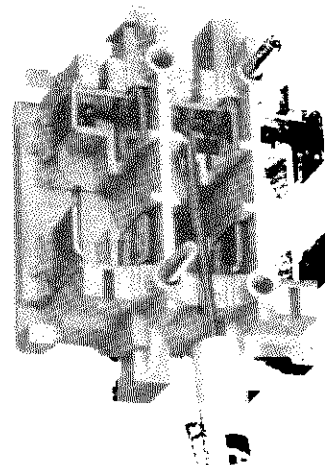
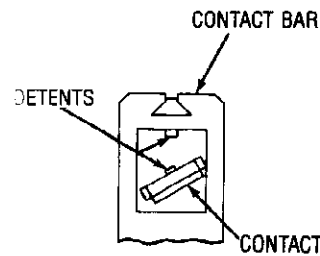
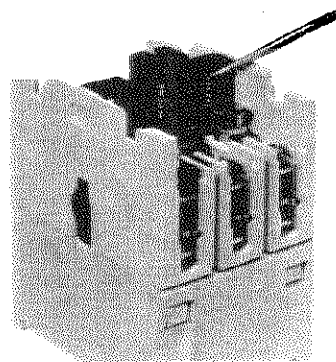

Figure 4



Sketch 'A'

Figure 5

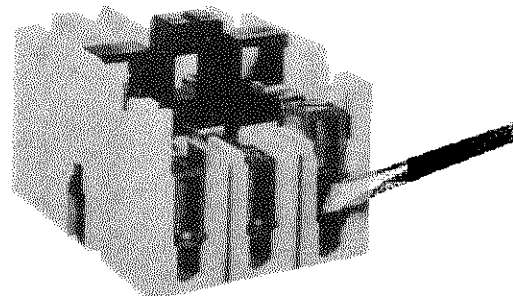
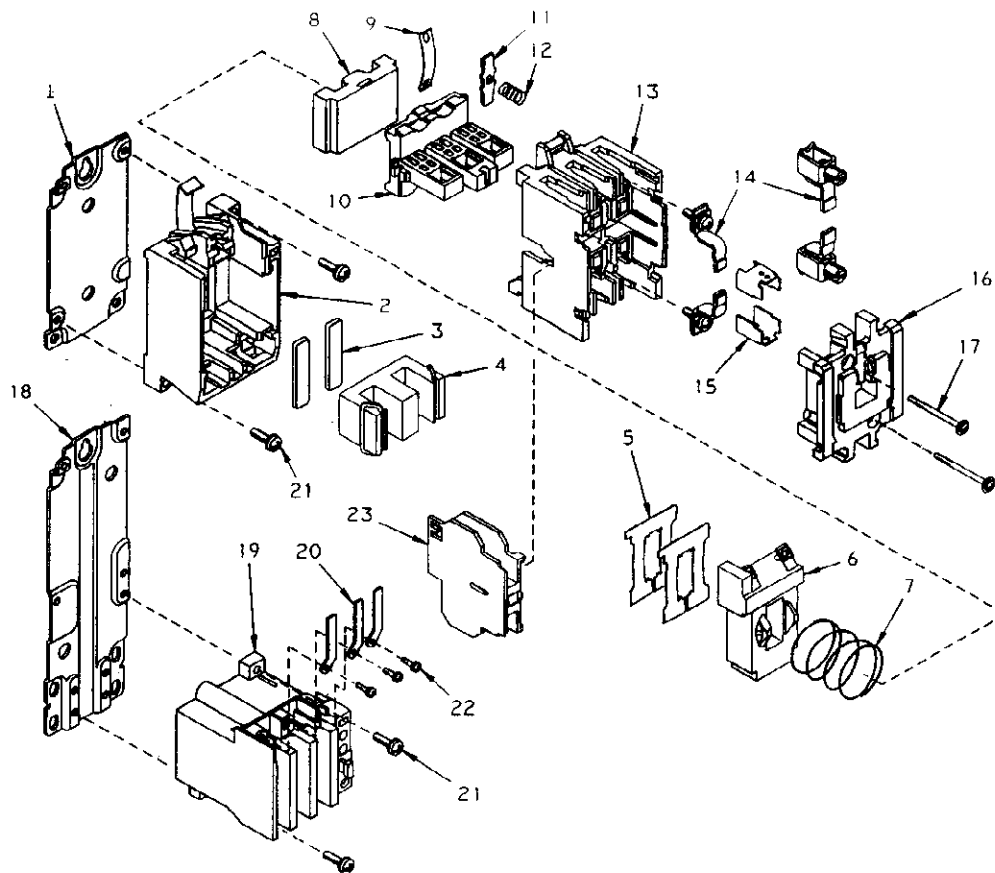

Figure 6



**RENEWAL PARTS - Information Required**

To insure prompt handling of renewal parts order, please include the following:

**DESCRIPTION, PART NUMBER, AND QUANTITY REQUIRED  
PARTS LIST**

ITEM NO.	DESCRIPTION	PART NUMBER	QUANTITIES				ITEM NO.	DESCRIPTION	PART NUMBER	QUANTITIES			
			CN15	AN16	CN55	AN56				CN15	AN16	CN55	AN56
1	Mounting Plate (contactors) Size 1, 1-3/4, and 2 Non-Reversing	—					19	Overload Relay (includes Items 20, 21, & 22)	C306GN3	-	1	-	1
	Reversing	C321MP2	1	-	-	-	20	Bus Bar Connector (includes Item 22):					
2	Lower Housing	49-7419	1	1	2	2		Size 1 Starter	25-10219-2	-	3	-	3
3	Shock Pad	32-1697	2	2	4	4		Size 1-3/4 & 2	25-10219-3	-	3	-	3
4	Magnet Frame *	17-18200	1	1	2	2	21	10-32 x .750 PH Sems Screw	11-5174	2	4	4	6
5	Coil Bias Spring	69-4747	2	2	4	4	22	8-32 x .203 Sems Screw	11-6194	-	3	-	3
6	Magnet Coil	See Page 2	1	1	2	2	23	Auxiliary Contact	See Page 4	2	1	2	4
7	Return Spring	69-4771	1	1	2	2	24	Renewal Contact Kit ** (incl Items 11, 12, 14, & 15)					
8	Armature Assembly *	48-1833	1	1	-	-		Size 1 2 Pole	6-65	1	1	-	-
9	Armature Retainer	69-6129	1	1	2	2		3 Pole	6-65-2	1	1	2	2
10	Contact Carrier	23-6337	1	1	2	2		Size 1-3/4 2 Pole	6-65-5	1	1	-	-
11	Movable Contact	See Item 24	-	-	-	-		3 Pole	6-65-6	-	1	2	2
12	Contact Spring	See Item 24	-	-	-	-		Size 2 2 Pole	6-65-7	1	1	-	-
13	Upper Housing (without markings)	49-7421	1	1	2	2		3 Pole	6-65-8	1	1	2	2
14	Stationary Contact Assembly	See Item 24	-	-	-	-		Size 2 2 Pole					
15	Arc Chute	See Item 24	-	-	-	-		3 Pole					
16	Cover Assembly (without markings) (Also includes Items 15 & 17)						25	Mechanical Interlock (not shown)	C321KM60B	1	-	1	1
	2 Pole	49-7425-2	1	-	-	-							
	3 Pole	49-7425	1	1	2	2							
17	Cover Screw	11-4989	2	2	4	4							
18	Mounting Plate (starters) Size 1, 1-3/4, & 2 Non-Reversing	—	1	1	1	1							
	Reversing	C321MP4	-	1	-	-							
		C321MP12	-	-	-	1							

\* It is recommended that Items 4 and 8 be replaced together.  
\*\* Recommended spare parts.

**RENEWAL OF OVERLOAD (Figure 7)**

The bimetal, ambient compensated overload relay is adjustable within the FLA ranges of the heater packs. Each heater pack is marked with range of FLA ratings.

Select heater packs (3 required) according to the motor FLA rating, and install in overload relay. Rotate the FLA adjustment dial to a position corresponding to the motor FLA. Consult overload relay publication supplied with the starter for proper setting and selection. The overload relay is factory set for manual operation. If automatic reset is required, turn the reset adjustment dial to "A" or "AUTO".

**THE ENTIRE OVERLOAD RELAY MUST BE REPLACED IF BURNOUT OF THE HEATER PACK OCCURS**

**Do not disassemble the overload relay!**

**Lubrication**

**Do not lubricate any part of this equipment.**

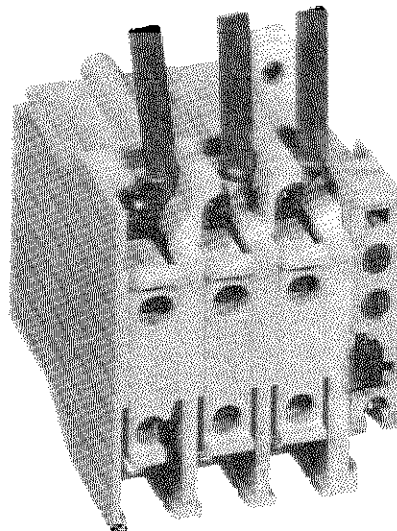

Fig. 7 - Overload Relay

**ACCESSORIES**

**Top Mounted Auxiliary Contacts**

Description	Standard Catalog No.	Logic Level Catalog No.
1 N.O.	C320KGT1	C320KGT1L
1 N.C.	C320KGT2	C320KGT2L
1 N.O. - 1 N.C.	C320KGT3	C320KGT3L
2 N.O.	C320KGT4	C320KGT4L
2 N.C.	C320KGT5	C320KGT5L
3 N.O.	C320KGT9	C320KGT9L
3 N.C.	C320KGT12	C320KGT12L
4 N.O.	C320KGT13	C320KGT13L
4 N.C.	C320KGT17	C320KGT17L

**Side Mounted Auxiliary Contacts**

Description	Standard Catalog No.	Logic Level Catalog No.
1 N.O.	C320KGS1	C320KGS1L
1 N.C.	C320KGS2	C320KGS2L
1 N.O. - 1 N.C.	C320KGS3	C320KGS3L
2 N.O.	C320KGS4	C320KGS4L
2 N.C.	C320KGS5	C320KGS5L
1 N.C.	C320KGD4 *	—
1 N.O. - 1 N.C.	C320KGD5 *	—

**NOTE:** For a complete list of available top and side mounted auxiliary contacts, see your local Eaton/Cutler-Hammer representative.

\*Used with DC magnet coil.

**Transient Suppressor**

Catalog No.	Coil Voltage
C320TS1	120V
C320TS2	240V
C320TS3	480V

**Pneumatic Timer**

Description	Catalog No.
0.1 to 30 sec.	C320TP1
10 to 30 sec.	C320TP2

**Electronic Timer**

Description	Catalog No.	
	120V AC/DC	240V AC/DC
0.3 to 3 sec.	C320TM3A	C320TM3B
3 to 30 sec.	C320TM30A	C320TM30B
30 to 300 sec.	C320TM300A	C320TM300B