

RENEWAL PARTS PUB NEMA SIZE 7 NON-REVERSING AND REVERSING CONTACTORS & STARTERS

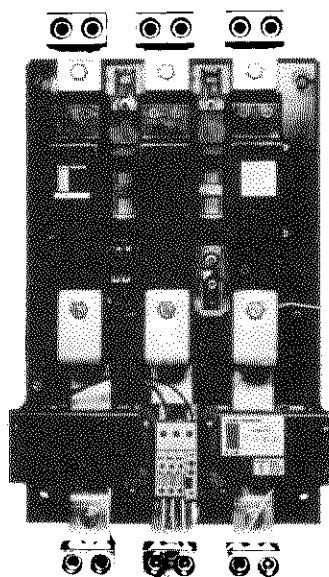

TYPICAL SIZE 7 STARTER

INTRODUCTION

This publication is design to simplify inspections and maintenance through the use of photographs and detail views for easy identification of parts. Illustrated steps on assembly and disassembly are shown. This information should be read carefully.

DESCRIPTION

This publication covers 3 pole, 3 phase non-reversing and reversing contactors and starters with ratings as shown on the nameplates.

CARE

These contactors/starters require no mechanical maintenance. If maintenance is needed, please note that these devices use metric hardware. All power contacts should be renewed at the same time before the contact tip material has worn away. Refer to publication 14183 for helpful information on inspecting and determining when to replace the contacts. When renewing contacts, check all terminal screws to insure they are tight and secure.

During routine electrical maintenance, the arc chutes are to be removed to inspect the main contacts for wear. Please note Fig. 4 exploded view drawing for service or repair.

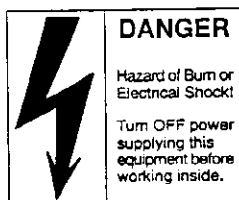

DANGER

Hazard of Burn or Electrical Shock!

Turn OFF power supplying this equipment before working inside.

All work on this contactor should be done with the main circuit disconnect device open. There is danger of electrocution and/or severe burns. Make certain that power is off. Also, disconnect power from any other external circuits.

ARC CHUTE REMOVAL

1. Disconnect all power to the contactor/starter.
2. Loosen the 4 screws attached to the arc chute.
3. Remove the arc chute.
4. To reinstall arc chute, reverse the above.

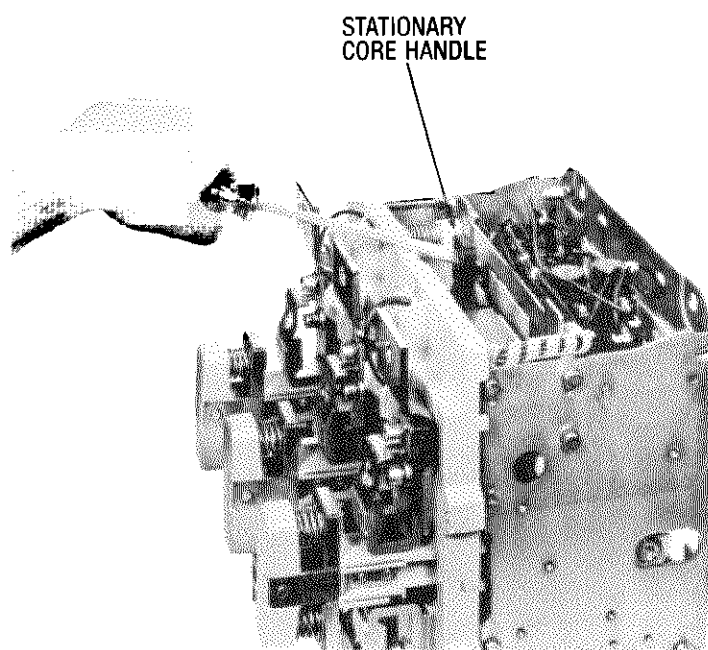

Fig. 1 -- COIL REMOVAL

MAIN COIL RENEWAL

Caution — If the device has been in service, many parts may still be thermally hot.

1. Disconnect all power to the contactor/starter.
2. Remove arc chute.
3. Loosen the 2 screws that secure each coil.
4. Remove feeder group cover and insert the tip of a long shaft screwdriver into the eye of the stationary core handle as shown in Fig. 1. Using the screwdriver as lever, gently pry stationary core upward until detents on the sliding blocks engage stop bars of contactor frame.
5. Grasp the coil by its handle and pull straight forward to remove.
6. Slide in new coils and tighten the screws to secure in place.
7. Reinsert stationary core into contactor by alternately compressing the right and left-hand sliding blocks, while pushing the stationary core down into the contactor until stationary core bottoms out.
8. Reinstall feeder group cover and arc chute.

Main Coils

Control Voltage		Main Coil Part No. 1 Required per Contactor
Volts	Hertz	
110-120	50/60	9-2698
220-240	50/60	9-2698-2
440-480	50/60	9-2698-3
550-600	50/60	9-2698-4
208	50/60	9-2698-5
380-415	50/60	9-2698-6
48-52	50/60	9-2698-8

NOTE: Voltage ratings of the main coils must match those of the feeder group for proper operation of the starter/contactator.

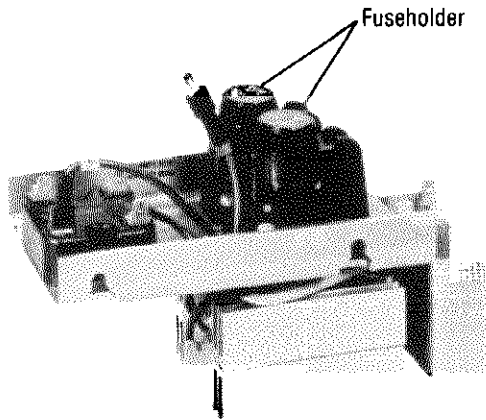

Fig. 2 - FEEDER GROUP

FEEDER GROUP

This is the panel assembly located beneath the feeder group cover. It supplies the main contactor coils with DC control voltage. See instruction pub for wiring diagram.

FEEDER GROUP RENEWAL

1. Disconnect all power to the contactor/starter.
2. Remove the feeder group cover.
3. Disconnect the 6 wires going to the feeder group.
4. Using a 8mm wrench, loosen the 4 hex head feeder group mounting screws and remove feeder group from contactor.
5. Reverse the above to install new feeder group.

Feeder Group Renewal

Control Voltage		Feeder Group (Complete)
Volts	Hertz	
110-120	50/60	9-2705
220-240	50/60	9-2705-2
440-480	50/60	9-2705-3
550-600	50/60	9-2705-4
208	50/60	9-2705-5
380-415	50/60	9-2705-6
48-52	50/60	9-2705-8

NOTE: Voltage ratings of feeder group must match those of the main coils for proper operation of the starter/contactor.

MAIN CONTACT RENEWAL

Caution — If the device was in service, the contacts may still be very hot.

1. Disconnect all power to the contactor/starter.
2. Remove arc chute.
3. Press down on the movable contact assembly until the locking pins become loose. Then remove locking pins by sliding them to the right or left. See Fig. 3.
4. Release pressure on the movable contact assembly and remove.
5. Remove stationary contacts by removing the allen screws. Use a 6mm allen wrench.
6. Install new stationary contacts and screws.
7. Assemble contact, springs, and spring retainers. Press down on the movable contact assembly and install the locking pins.
8. Install arc chute.

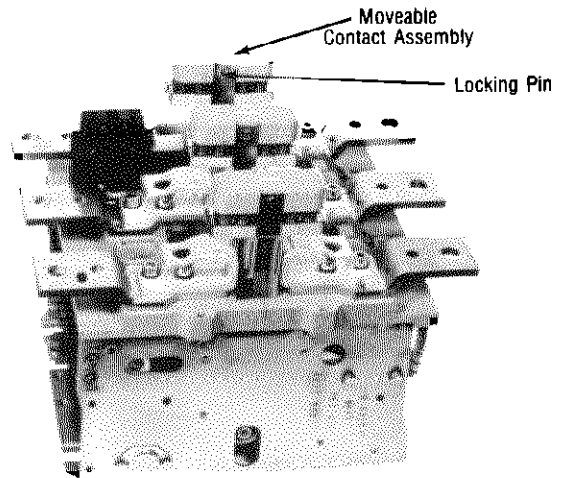

Fig. 3 - MAIN CONTACT RENEWAL

RENEWAL OF CURRENT TRANSFORMER

1. Disconnect all power to the starter.
2. Remove the 2 screws holding the top plate to the right-hand side plate. This will allow the top plate to swing away from the transformers.
3. Disconnect the transformer wiring.
4. Remove the mounting hardware that secures the bus bar connectors which pass through the transformer.
5. Remove the four screws that secure the transformer to the mounting panel. Note the location of the polarity marking.
6. Remove the bus bar connectors and the transformer.
7. Reinstall new transformer by reversing the above. Make sure the transformer polarity is correct. Refer to instruction publication for wiring diagram.

RENEWAL OF BIMETAL OVERLOAD RELAY

This bimetal, ambient compensated overload relay is adjustable within the **FLA** range of the heater pack. Each heater pack is marked with its range of **FLA** ratings.

Select heater pack (**3 required**) according to the motor **FLA** rating and install in overload relay. Rotate **FLA** adjustment dial to a position corresponding to the motor **FLA**. Consult **overload relay publication supplied with the starter for proper setting and selection**. The overload relay is factory set for manual reset operator. If automatic reset is required, turn the reset adjustment dial to "Auto".

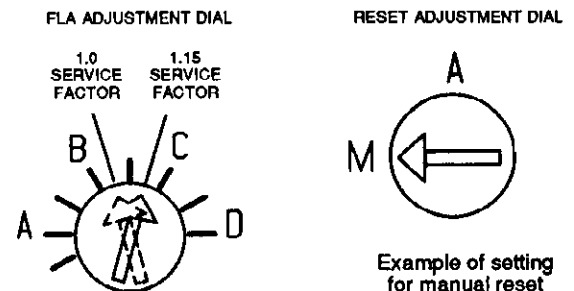

The entire overload relay must be replaced if burnout of the heater occurs.

DO NOT disassemble this relay!

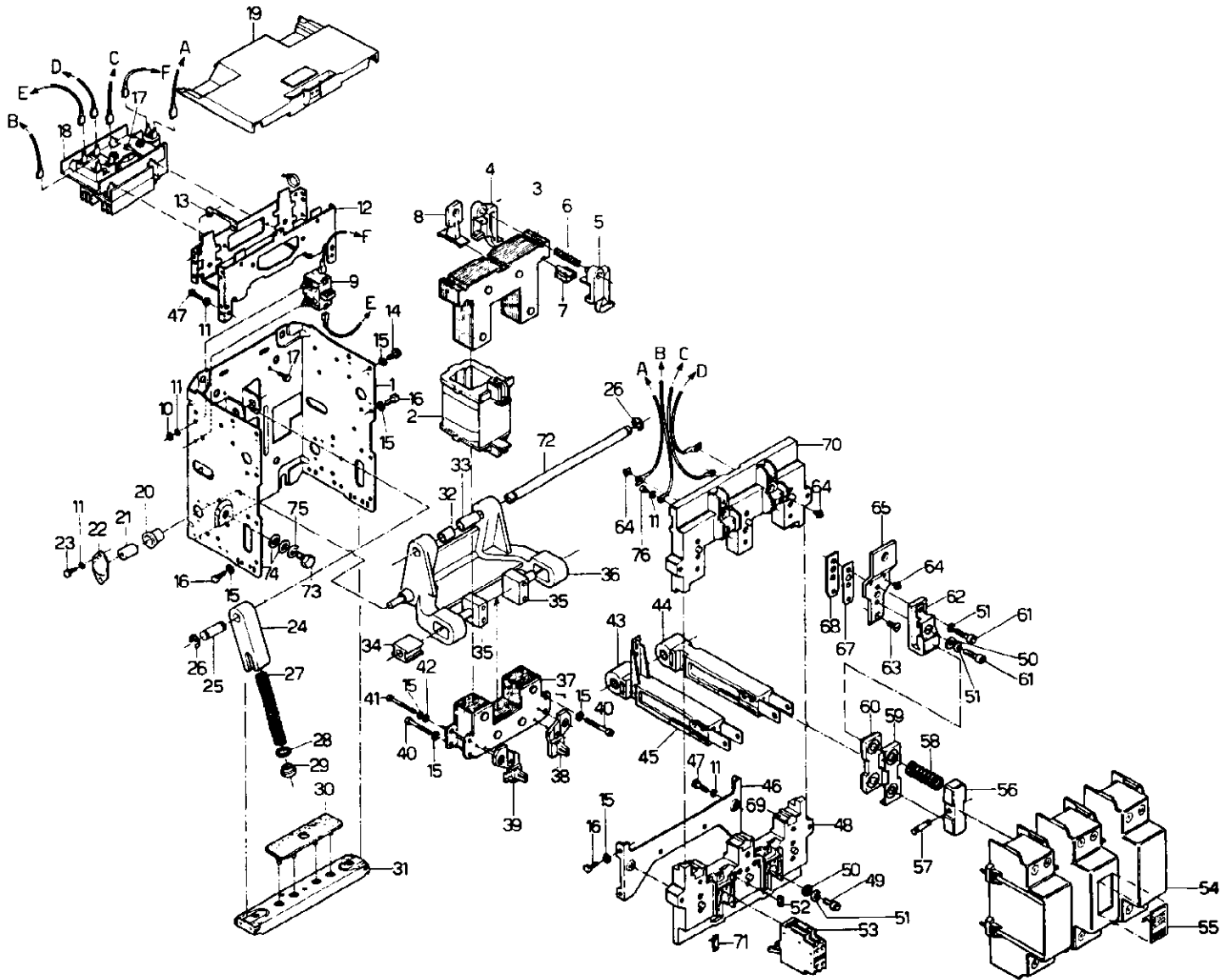

FIG. 4

(FIGS. 4 & 5)

ITEM NO.	DESCRIPTION	PART NUMBER	QUANTITIES			
			CN15	AN16	CN55	AN56
1	Contacting Frame		1	1	2	2
2	Main Coil Set ▲▲	See Table, P. 1	1	1	2	2
3	Stationary Core		1	1	2	2
4	Right Sliding Block	See Item 88	2	2	4	4
5	Left Sliding Block	See Item 88	2	2	4	4
6	Sliding Block Spring	See Item 88	2	2	4	4
7	Core Stop	See Item 88	2	2	4	4
8	Stationary Core Handle	See Item 89	1	1	2	2
9	Saving Resistor-AC Interlock	10-6144	1	1	2	2
10	M5x3.5, Hex Nut		2	2	4	4
11	5.3m, Spring Washer		12	12	24	24
12	Stationary Core Support		1	1	2	2
13	Core Stop Plate		2	2	4	4
14	M6x12, Screw		4	4	8	8
15	6.3m, Lockwasher		24	24	48	48
16	M6x10, Hex Screw		16	16	32	32
17	M5x7, Hex Screw		4	4	8	8
18	Feeder Group (complete)	See Table, P. 2 for voltage selection	1	1	2	2
19	Feeder Group Cover	56-6190	1	1	2	2
20	Lever Flange		2	2	4	4
21	Lever Bushing		2	2	4	4
22	Flange Plate		2	2	4	4
23	M5x8, Hex Screw		4	4	8	8
24	Return Spring Lever		1	1	2	2
25	Return Spring Pivot		1	1	2	2
26	Locking Ring		4	4	8	8
27	Return Spring Washer		1	1	2	2
28	Return Spring Washer		1	1	2	2
29	Return Spring Slide		1	1	2	2
30	Shock Absorber		1	1	2	2
31	Moving Core Cross Bar		1	1	2	2
32	Spacer		1	1	2	2
33	Spacer (long)		1	1	2	2
34	Core Bushing		2	2	4	4
35	Pivot Support		2	2	4	4
36	Core Lever		1	1	2	2
37	Moving Core		1	1	2	2
38	Right Aux. Driver		1	1	2	2
39	Left Aux. Driver		1	1	2	2
40	M6x45, Hex Screw		4	4	8	8
41	M6x50, Hex Screw		4	4	8	8
42	6.4m, Flat Washer		4	4	8	8
43	Moving Contact Holder (pole 1)		1	1	2	2
44	Moving Contact Holder (poles 2 & 3)		1	1	2	2
45	Slide		3	3	6	6
46	Lower Base Support		1	1	2	2
47	M5x10, Hex Screw		4	4	8	8
48	Lower Base		1	1	2	2
49	M8x16, Hex Screw		4	4	8	8
50	8.4m, Flat Washer		10	10	20	20
51	8.4m, Lockwasher		16	16	32	32
52	Arc Chute Grommet		4	4	8	8
53	Auxiliary Contact (2NO-2NC)	C320KA6	1	1	2	2

ITEM NO.	DESCRIPTION	PART NUMBER	QUANTITIES			
			CN15	AN16	CN55	AN56
54	Arc Chute Assy	62-874	1	1	2	2
55	Label (not supplied)		-	-	-	-
56	Spring Retainer		3	3	6	6
57	Retaining Pin		3	2	6	6
58	Contact Spring		24	24	48	48
		Items 56 thru 62 supplied with contact kit, Item 87	▲	-	-	-
59	Bridge		6	6	12	12
60	Moving Contact		6	6	12	12
61	M8x25 Allen Head Screws		12	12	24	24
62	Stationary Contact		3	3	6	6
63	M6x16, Screw		6	6	12	12
64	Wire Clamp		6	6	12	12
65	Bus Bar		6	6	12	12
66	Bus Bar (not shown)	25-7253	-	-	6	6
67	0.5mm Shim Plate		6	6	12	12
68	3mm Shim Plate		6	6	12	12
69	Contact Holder Slide		3	3	6	6
70	Upper Base		1	1	2	2
71	On/Off Label		1	1	2	2
72	Core Lever Rod		1	1	2	2
73	M10x16, Hex Screw		1	1	2	2
74	10.5m, Flat Washer		2	2	4	4
75	10.5m, Lockwasher		1	1	2	2
76	M5x7, Hex Screw		2	2	4	4
77	Fuse Holder (See Fig. 2, includes mounting screws)	C320FBR	2	2	4	4
78	Lug (750MCM-3 wire)	80-6626	6	6	6	6
79	1/2-13 x 1.75 Hex Head Screw	911-5894Z	6	3	12	9
	3/8-16 x 1.75 Hex Head Screw	911-5654Z	6	6	12	12
80	1/2-13 Hex Nut	915-1403Z	6	6	12	12
	3/8-16 Hex Nut	915-1004Z	6	3	12	9
	1/2 Lockwasher	916-199	6	6	12	12
	3/8 Lockwasher	916-23	6	3	12	9
81	Bus Bar	25-8139	-	3	-	3
82	Side Plate	47-28267	-	2	-	2
83	Insulator (not shown)	56-5980	-	3	-	3
84	Current Transformer	42-3598-2	-	1	-	1
85	Terminal Base Adapter	10-6380-2	-	1	-	1
86	Overload Relay	C308DN3	-	1	-	1
87	Contact Kit (not shown) includes Items 50, 51, & 56 thru 62)					
	3 Pole Kit	6-613	1	1	2	2
88	Magnet Repair Kit (includes Items 4 thru 7)	99-2890	1	1	2	2
89	Stationary Core Handle Repair Kit	99-2891	1	1	2	2

▲▲ 1 main coil set = 2 separate coils

NOTE: Only the parts listed with a part number are available for replacement. All other parts are shown and described for identification only.

**FOR A50 AND C50 DEVICES ONLY
VERTICAL MECHANICAL INTERLOCK**

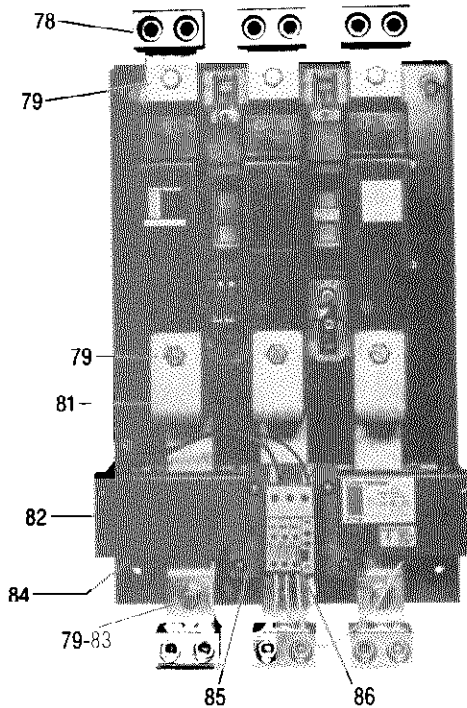

Fig. 5

AUXILIARY INTERLOCKS (Fig. 6)

The electrical interlocks are renewable as a complete assembly and are available in a 2 NO-2 NC configuration.

Little care is required for the interlocks beyond occasional examination to ensure that parts move freely without interference or binding.

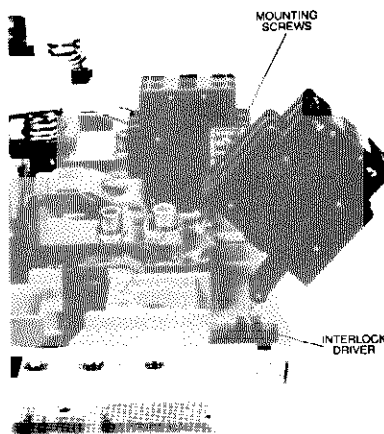

Fig. 6

INSTALLATION INSTRUCTIONS

1. Insert operating lever of auxiliary interlock into left or right-hand interlock driver of contactor.
2. Align mounting screws of auxiliary contact with integral inserts on contactor frame and tighten screws to secure auxiliary interlock to contactor.

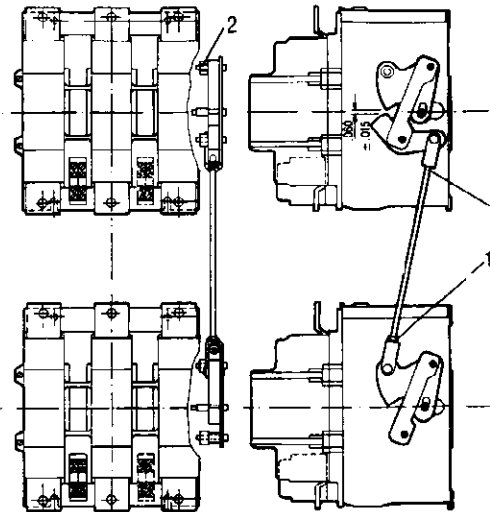

Fig. 7

ADJUSTMENT (Fig. 7)

1. Tighten item 1 on lowest lever. (Bushing in U bracket will rotate.)
2. Adjust rod length so that points of upper levers are in line with each other.
3. Adjust hex bushing (item 2) to obtain $.060 \pm .015$ between cams as shown in Figure 7.
4. Cams must not touch during initial stroke of either contactor.

MAINTENANCE AND RENEWAL OF MAGNET CORE STOPS

The contactor should be periodically inspected for wear or erosion of the magnet core stops, Figure 4 - Item 7. If this inspection reveals that the core stops should be replaced, order the magnet repair kit listed in Figure 4, Item 88.

1. Disconnect all main power to the contactor/starter.
2. Remove feeder group cover, Fig. 4 - Item 19.
3. Energize power to contactor magnet coil.
4. Observe top of saving resistor interlock Fig. 4 - Item 9, and compare to Sketches "A" and "B".
5. If the white indicator appears as shown in Sketch "A", the core stops are still serviceable. If the white indicator appears as shown in Sketch "B", the core stops should be replaced.

