



Cutler-Hammer

Motor Control Center Type Freedom Unitrol

Renewal Parts

Supersedes RP.03A.04.S.E
pages 1-28, dated September 2000

Description

Page

Motor Control Center Type Freedom Unitrol

Distributor Ordering Instructions	2
Procedure for Identifying MCC Renewal Units and Parts	2
Identifying Motor Control Center Types	3
Identification by Original Handle Mechanism	3
Procedure for Identifying Motor Control Center Types	4
Freedom Unitrol Product Description	5
Replacement Starter Units	6 – 14
Unit Options	15 – 17
Structure Parts	18 – 22
Unit Parts	23 – 26
Replacement Feeder Units (All Vintages)	28

MCC Type	Dates	Cutler-Hammer Renewal Parts Publication
F2100 Advantage™ Series 2100	1995 – 1992 – 1987 – 95	RP04304001E RP04304002E RP04304003E
5 Star Freedom Unitrol F10 Unitrol	1975 – 87 1988 – 94 1972 – 89	RP04304003E RP04304004E RP04304005E
Type W 9800 Unitrol 11-300	1965 – 75 1956 – 74 1935 – 65	RP04304006E RP04304007E RP04304008E

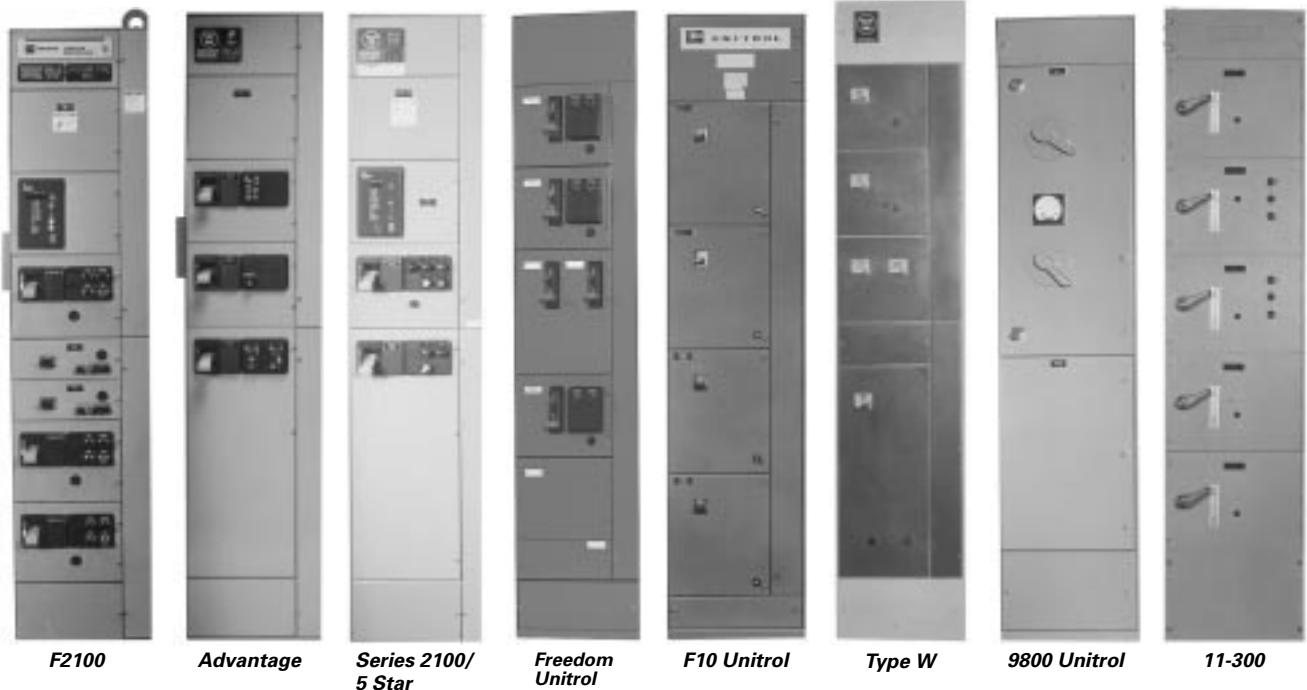

Distributor Ordering Instructions

1. Specify the item by catalog or style number.
2. For pricing information, refer to Price List PL04304002E (formerly PL 8991A dated November 1997).
3. Enter the order on VISTALINE™ on Suffix **FVU**, or through e-POD on Suffix **FVU**.
4. Selling Policy 25-000 (SP03000001E) applies, the Discount Symbol is **1CD-2C**.

Procedure for Identifying Motor Control Centers Renewal Units and Parts

1. Identify the design of the Eaton's Cutler-Hammer Motor Control Center (MCC) from the data found on the nameplate. Critical information includes:
 - Type of MCC.
 - Type of contactor.
 - Door width.
 - Bucket width.

Note: In the event that the nameplate is missing or unreadable, follow the procedure on **Page 4**.
2. Refer to **Pages 5** through **26** and turn to the section in this Renewal Parts to identify replacement units, options, structure parts, and unit parts for Freedom Unitrol.
3. For Replacement Feeder Units, refer to **Page 28**.
4. This publication identifies those replacement units and parts which are most frequently ordered. Units should be ordered by complete catalog number, and parts by complete style number.

For parts not listed or shown, contact your authorized Cutler-Hammer distributor or local Cutler-Hammer sales representative.

5. If additional assistance is required, contact the Motor Control Center Aftermarket Product Center in Fayetteville, NC at **(910) 483-2222** or **1-800-OLD-UNIT** or Fax (910) 677-5208 or (910) 677-5272.

You can also contact one of our eight Service Centers for assistance with F2100, Advantage, Series 2100/5 Star, Freedom Unitrol, F10 Unitrol, Type W, 11-300 and 9800 Unitrol Motor Control Centers.

Atlanta

Phone (770) 739-6282
Fax (770) 739-7178

Chicago

Phone (847) 299-1911
Fax (847) 299-0398

Cincinnati

Phone (513) 682-4000
Fax (513) 682-4004

Denver

Phone (303) 373-2133
Fax (303) 375-9095

Hartford

Phone (860) 683-4221
Fax (860) 683-0764

Houston

Phone (713) 939-9696
Fax (713) 939-0427

Los Angeles

Phone (562) 944-6413
Fax (562) 941-7178

Portland

Phone (503) 636-8333
Fax (503) 636-8545

Identifying Motor Control Center Types

In most cases, it is possible to identify MCC design by handle type. Starter type, bucket width and door width can assist in identification.

Table 1. Identifying Motor Control Center Types

MCC Type	Type of Handle Mechanism	Original MCC Starter Type	Bucket Width Inches (mm)	Door Width Inches (mm)	Original Manufacturer ①	Starter Type (Installed in New Unit)
F2100 ②	Lever	Freedom Series	13-3/4 (349.3)	15-5/8 (397.0)	Cutler-Hammer 1994 to Present	Freedom
Advantage ②	Lever	Advantage	13-3/4 (349.3)	15-5/8 (397.0)	Westinghouse until 1994 Cutler-Hammer 1994 to Present	Advantage
Series 2100 ②	Lever	A200	13-3/4 (349.3)	15-5/8 (397.0)	Westinghouse until 1994 Cutler-Hammer 1994 to Present	A200
5 Star ②	Lever	A200	13-3/4 (349.3)	15-5/8 (397.0)	Westinghouse 1975 – 1987	A200
Freedom Unitrol	Slider	Freedom Series	13-7/8 (352.5)	15-1/2 (393.7)	Cutler-Hammer 1988 – 1994	Freedom
F10 Unitrol	Slider and Lever	Citation	14 (355.6)	14-3/4 (374.7) w/ Wireway 19-1/2 (495.3) w/o Wireway	Cutler-Hammer 1972 – 1989	Freedom
Type W	Slider	A200 or 11-200	11-3/4 (298.5)	13-3/8 (339.9)	Westinghouse 1965 – 1975	A200
9800 Unitrol	Rotary ③	3 Star/Citation	16-1/8 (409.7)	19-3/8 (492.3)	Cutler-Hammer 1956 – 1974	Freedom
11-300	Rotary	11-200 Lifeline Type N/A200	15-3/4 (400.1)	20 (508.0)	Westinghouse 1950 – 1965	A200

① MCC types were sometimes produced outside the time spans shown. This was due to the overlap of production when a new design was adopted.

② The unit “wrappers” are mechanically identical for these designs.

③ 9800 originally was supplied with Rotary. New replacement units are manufactured with slider handle mechanism.

Identification by Original Handle Mechanism



*F2100, Advantage,
Series 2100/5 Star*



Freedom Unitrol



*F10 Unitrol Slider
9800 Unitrol*



*F10 Unitrol Lever
and 9800 Unitrol*



Type W



9800 Unitrol

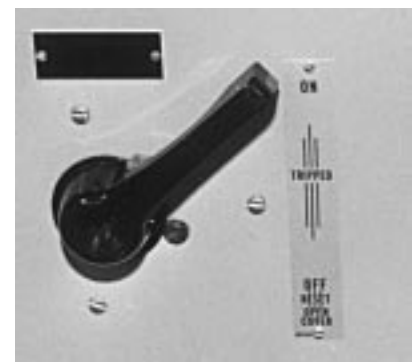

11-300

Procedure for Identifying Motor Control Center Types

In the event that the nameplate is missing, it is possible to identify the MCC design by the type of handle mechanism, starter type, bucket width and door width.

Table 2. Identifying Motor Control Center Types

MCC Type	Type of Handle Mechanism	Starter Type	Bucket Width Inches (mm)	Door Width Inches (mm)	Cutler-Hammer Renewal Parts Publication
F2100 Advantage Series 2100	Lever Lever Lever	Freedom Series Advantage A200	13-3/4 (349.3) 13-3/4 (349.3) 13-3/4 (349.3)	15-5/8 (397.0) 15-5/8 (397.0) 15-5/8 (397.0)	RP04304001E RP04304002E RP04304003E
5 Star Freedom Unitrol F10 Unitrol	Lever Slider Lever/Slider	A200 Freedom Series Citation	13-3/4 (349.3) 13-7/8 (352.5) 14 (355.6)	15-5/8 (397.0) 15-1/2 (393.7) 14-3/4 (374.7) w/ Wireway or 19-1/2 (495.3) w/o Wireway	RP04304003E RP04304004E RP04304005E
Type W 9800 Unitrol 11-300	Slider Rotary Rotary	A200 or 11-200 3 Star and/or Citation 11-200 Life-line N and/or A200	11-3/4 (298.5) 16-1/8 (409.7) 15-3/4 (400.1)	13-3/8 (339.9) 19-3/8 (492.3) 20 (508.0)	RP04304006E RP04304007E RP04304008E



F2100

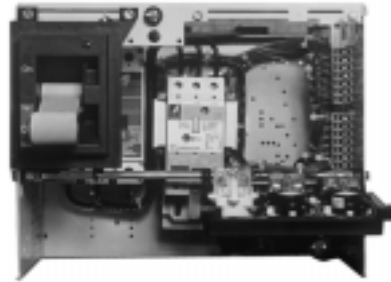

Advantage



Series 2100/5 Star

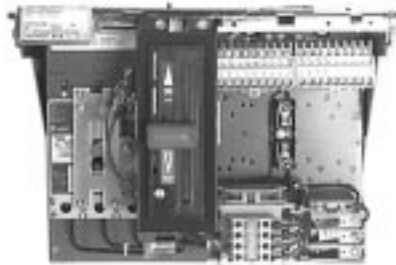

Freedom Unitrol

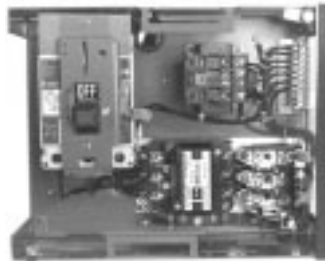

F10 Unitrol



Type W



9800 Unitrol



11-300

Freedom Unitrol Product Description

Introduced in 1989, this Cutler-Hammer MCC had vertical structures that measured 20 inches (508.0 mm) wide, 91-1/2 inches (2324.1 mm) high and either 15 inches (381.0 mm) or 20 inches (508.0 mm) deep. It allowed a 6-inch (152.4 mm) size 1 unit design.

ANSI 49 was applied to the units, structural framework, roof, side sheets, and all exterior doors.

The Freedom Unitrol utilized the Freedom starter and was identified by the slider type handle mechanism. Bus and bus support systems were typically braced to withstand fault currents of 42,000A with the option to increase to 65,000A.

Table 3. Freedom Unitrol Product Rating

Maximum Ratings
3-Phase, 600V, 400 hp, 2500A Bus

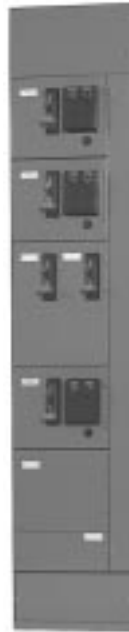

*Freedom Unitrol
Structure*

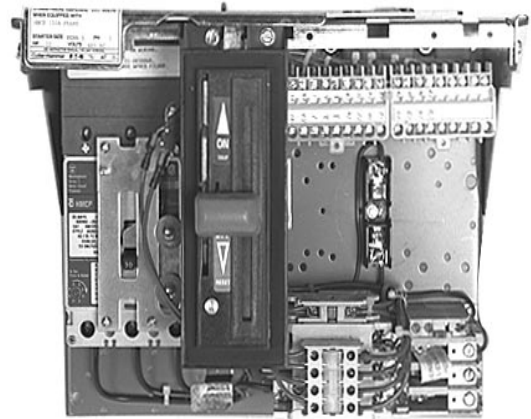

Freedom Unitrol Starter Unit

Freedom Unitrol Replacement Starter Units

How to Order

When ordering a replacement unit, you receive:

- Series C® HMCP.
- Freedom Starter.
- Unit options as specified.
- New steel wrapper, door and handle mechanism.
- New stabs.
- UL® label.

Use the following steps for creating a catalog number for your specific application:

Step 1

Select the correct replacement unit from **Pages 6 – 14**. When selecting, you need to know the following:

- MCC type.
- Class of Unit (FVNR, FVR, Reduced Voltage — Autotransformer or Part Winding or Solid State, FV – 2 Speed, 1 Winding or 2 Speed, 2 Winding, etc.).
- Starter size or horsepower rating.
- Protection device (breaker or fusible).
- Service voltage.
- Control voltage.
- Space required.

Step 2

Verify required space is available.

Step 3

Create a catalog number by selecting Catalog Codes from the columns per the example given.

Step 4

Add modifications as required from the Unit Options on **Pages 15 – 17**. Space available determines allowable options.

Table 4. Catalog Numbering System Example

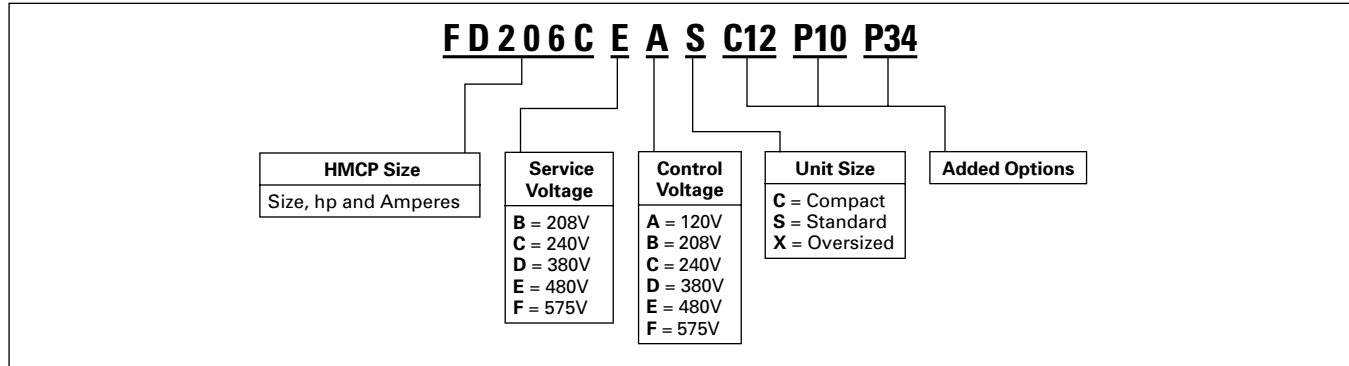

Table 5. Full Voltage Non-Reversing Combination Starter — HMCP (Must specify if HMCP E is required)

NEMA® Size	Maximum Horsepower					HMCP Size	Catalog Code	Service Voltage	Catalog Code	Control Voltage	Catalog Code	Space Options Inches (mm)	Catalog Code						
	208V	240V	380V	480V	600V														
1	0.5	0.33	1	1	1.5	3	FD206A FD206B FD206C FD206D	208 240 380 480 575	B C D E F	120 208 240 380 480 575	A B C D E F	6 (152.4) High 12 (304.8) High 18 (457.2) High	C ^① S X						
	1	1	2	3	3									7					
	3	3	5	7.5	7.5									15					
	7.5	7.5	10	10	10									30					
2	10	15	25	25	25	50	FD206E	208 240 380 480 575	B C D E F	120 208 240 380 480 575	A B C D E F	12 (304.8) High 18 (457.2) High	S X						
														208	208	240	380	480	575
														380	240	380	480	575	
														480	240	380	480	575	
														575	240	380	480	575	
3	25	30	50	50	100	FD206H	208 240 380 480 575	B C D E F	120 208 240 380 480 575	A B C D E F	18 (457.2) High 24 (609.6) High	S X							
													208	120	208	380	480	575	
													240	120	208	380	480	575	
													380	120	208	380	480	575	
													480	120	208	380	480	575	
4	40	50	75	100	150	FD206L	208 240 380 480 575	B C D E F	120 208 240 380 480 575	A B C D E F	18 (457.2) High 24 (609.6) High	S X							
													208	120	208	380	480	575	
													240	120	208	380	480	575	
													380	120	208	380	480	575	
													480	120	208	380	480	575	
5	60 75	60 100	125 150	150 200	250 400	FD206P FD206R	208 240 380 480 575	B C D E F	120 208 240 380 480 575	A B C D E F	48 (1219.2) High	S							
													208	120	208	380	480	575	
													240	120	208	380	480	575	
													380	120	208	380	480	575	
													480	120	208	380	480	575	

① On 6-inch (152.4 mm) units, the only options available are (3) E22 pilot devices and separate source fuse or disconnect or CPT.

Freedom Unitrol Replacement Starter Units

Table 6. Full Voltage Reversing Combination Starter — HMCP

NEMA Size	Maximum Horsepower					HMCP Size	Catalog Code	Service Voltage	Catalog Code	Control Voltage	Catalog Code	Space Options Inches (mm)	Catalog Code	
	208V	240V	380V	480V	600V									
1	0.5	0.33	1	1	1.5	3	FD216A FD216B FD216C FD216D	208	B C D E F	120	A B C D E F	18 (457.2) High 24 (609.6) High	S X	
	1	1	2	3	3	7		240		208				
	3	3	5	7.5	7.5	15		380		240				
	7.5	7.5	10	10	10	30		480		380				
								575		480				
2	10	15	25	25	25	50	FD216E	208	B C D E F	120	A B C D E F	18 (457.2) High 24 (609.6) High	S X	
	10	15	25	25	25	50		240		208				
								380		240				
								480		380				
								575		480				
3	25	30	50	50	50	100	FD216H	208	B C D E F	120	A B C D E F	30 (762.0) High	S	
	25	30	50	50	50	100		240		208				
								380		240				
								480		380				
								575		480				
4	40	50	75	100	100	150	FD216L	208	B C D E F	120	A B C D E F	30 (762.0) High	S	
	40	50	75	100	100	150		240		208				
								380		240				
								480		380				
								575		480				
5	50	60	100	125	150	250	FD216P FD216R	208	B C D E F	120	A B C D E F	72 (1828.8) High	S ^①	
	75	100	150	200	200	400		240		208				
	50	60	100	150	200	200		400		380				240
										480				380
										575				480
							575							

① Full size bolt-in panel.

Table 7. Full Voltage 2 Speed 1 Winding — Constant/Variable Torque — HMCP^②

NEMA Size	Maximum Horsepower					HMCP Size	Catalog Code	Service Voltage	Catalog Code	Control Voltage	Catalog Code	Space Options Inches (mm)	Catalog Code	
	208V	240V	380V	480V	600V									
1	0.5	0.33	1	1	1.5	3	FD946A FD946B FD946C FD946D	208	B C D E F	120	A B C D E F	24 (609.6) High 36 (914.4) High	S X	
	1	1	2	3	3	7		240		208				
	3	3	5	7.5	7.5	15		380		240				
	7.5	7.5	10	10	10	30		480		380				
								575		480				
2	10	15	25	25	25	50	FD946E	208	B C D E F	120	A B C D E F	24 (609.6) High 36 (914.4) High	S X	
	10	15	25	25	25	50		240		208				
								380		240				
								480		380				
								575		480				
3	25	30	50	50	50	100	FD946H	208	B C D E F	120	A B C D E F	48 (1219.2) High	S	
	25	30	50	50	50	100		240		208				
								380		240				
								480		380				
								575		480				
4	40	50	75	100	100	150	FD946L	208	B C D E F	120	A B C D E F	60 (1524.0) High	S	
	40	50	75	100	100	150		240		208				
								380		240				
								480		380				
								575		480				
5	50	60	100	125	150	250	FD946P FD946R	208	B C D E F	120	A B C D E F	72 (1828.8) High	S ^③	
	75	100	150	200	200	400		240		208				
	50	60	100	150	200	200		400		380				240
										480				380
										575				480
							575							

② For constant horsepower instead of constant/variable torque, see Option SV6 on Page 17.

③ Full size bolt-in panel.

Freedom Unitrol Replacement Starter Units

Table 8. Full Voltage 2 Speed 2 Winding — Constant/Variable Torque — HMCP ①

NEMA Size	Maximum Horsepower					HMCP Size	Catalog Code	Service Voltage	Catalog Code	Control Voltage	Catalog Code	Space Options Inches (mm)	Catalog Code																	
	208V	240V	380V	480V	600V																									
1	0.5	0.33	1	1	1.5	3	FD956A	208	B	120	A	24 (609.6) High	S																	
	1	1	2	3	3	7	FD956B	240	C	208	B																			
	3	3	5	7.5	7.5	15	FD956C	380	D	240	C																			
	7.5	7.5	10	10	10	30	FD956D	480	E	380	D																			
														575	F	480	E													
2	10	15	25	25	50	FD956E	208	B	120	A	24 (609.6) High	S																		
													240	C	208	B														
																	380	D	240	C										
																					480	E	380	D						
																									575	F	480	E		
3	25	30	50	50	100	FD956H	208	B	120	A	36 (914.4) High	S																		
													240	C	208	B														
																	380	D	240	C										
																					480	E	380	D						
																									575	F	480	E		
4	40	50	75	100	150	FD956L	208	B	120	A	48 (1219.2) High	S																		
													240	C	208	B														
																	380	D	240	C										
																					480	E	380	D						
																									575	F	480	E		
5	50	60	100	125	250	FD956P	208	B	120	A	72 (1828.8) High	S ②																		
													75	100	150	200	400	FD956R	240	C	208	B								
																							380	D	240	C				
																											480	E	380	D

① For constant horsepower instead of constant/variable torque, see Option SV6 on Page 17.

② Full size bolt-in panel.

Table 9. Reduced Voltage Autotransformer — HMCP

NEMA Size	Maximum Horsepower					HMCP Size	Catalog Code	Service Voltage	Catalog Code	Control Voltage	Catalog Code	Space Options Inches (mm)	Catalog Code																		
	208V	240V	380V	480V	600V																										
2	10	15	25	25	25	50	FD606E	208	B	120	A	48 (1219.2) High	S ③																		
														240	C	208	B														
																		380	D	240	C										
																						480	E	380	D						
																										575	F	480	E		
3	25	30	50	50	100	FD606H	208	B	120	A	60 (1524.0) High	S ③																			
													240	C	208	B															
																	380	D	240	C											
																					480	E	380	D							
																									575	F	480	E			
4	40	50	75	100	150	FD606L	208	B	120	A	72 (1828.8) High	S ③																			
													240	C	208	B															
																	380	D	240	C											
																					480	E	380	D							
																									575	F	480	E			
5	30	50	75	125	250	FD606P	208	B	120	A	72 (1828.8) High	S ③																			
													30	50	75	200	100	400	FD606R	240	C	208	B								
																								380	D	240	C				
																												480	E	380	D

③ If existing MCC is back-to-back design, 36 inches (914.4 mm) in bottom rear is unusable.

Freedom Unitrol Replacement Starter Units

Table 10. Reduced Voltage Part Winding — HMCP

NEMA Size	Maximum Horsepower					HMCP Size	Catalog Code	Service Voltage	Catalog Code	Control Voltage	Catalog Code	Space Options Inches (mm)	Catalog Code
	208V	240V	380V	480V	600V								
1	10	10	15	15	15	30	FD706D	208 240 380 480 575	B C D E F	120 208 240 380 480 575	A B C D E F	24 (609.6) High	S
2	20	25	40	40	40	100	FD706F	208 240 380 480 575	B C D E F	120 208 240 380 480 575	A B C D E F	24 (609.6) High	S
3	40	50	75	75	75	150	FD706J	208 240 380 480 575	B C D E F	120 208 240 380 480 575	A B C D E F	30 (762.0) High	S
4	—	—	—	100	125	250	FD706L	208 240 380 480 575	B C D E F	120 208 240 380 480 575	A B C D E F	36 (914.4) High	S
	75	75	150	150	150	400	FD706M	208 240 380 480 575				48 (1219.2) High	
5	100 150	125 150	— 250	250 350	300 350	400 600	FDS706R FD706T	208 240 380 480 575	B C D E F	120 208 240 380 480 575	A B C D E F	72 (1828.8) High	S ^①

① Full size bolt-in panel.

Table 11. Reduced Voltage Wye Delta Open Transition — HMCP

NEMA Size	Maximum Horsepower					HMCP Size	Catalog Code	Service Voltage	Catalog Code	Control Voltage	Catalog Code	Space Options Inches (mm)	Catalog Code
	208V	240V	380V	480V	600V								
2	20	25	40	40	40	100	FD806F	208 240 380 480 575	B C D E F	120 208 240 380 480 575	A B C D E F	30 (762.0) High	S
3	40	50	75	75	75	150	FD806J	208 240 380 480 575	B C D E F	120 208 240 380 480 575	A B C D E F	36 (914.4) High	S
4	60 —	75 —	125 150	150 —	150 —	250 400	FD806M FD806N	208 240 380 480 575	B C D E F	120 208 240 380 480 575	A B C D E F	60 (1524.0) High	S
	100 150	125 150	200 250	250 350	300 —	400 600	FD806R FD806T	208 240 380 480 575				72 (1828.8) High	

② Full size bolt-in panel.

Freedom Unitrol Replacement Starter Units

Table 12. Reduced Voltage Wye Delta Closed Transition — HMCP (Non-Chiller Application)

NEMA Size	Maximum Horsepower					HMCP Size	Catalog Code	Service Voltage	Catalog Code	Control Voltage	Catalog Code	Space Options Inches (mm)	Catalog Code
	208V	240V	380V	480V	600V								
2	20	25	40	40	40	100	FD896F	208	B C D E F	120	A B C D E F	36 (914.4) High	S
								240		208			
								380		240			
								480		380			
								575		480			
								575		575			
3	40	50	50	50	100	FD896J	208	B C D E F	120	A B C D E F	42 (1066.8) High	S	
							240		208				
							380		240				
							480		380				
							575		480				
							575		575				
4	60 —	75 —	125 150	150 —	150 —	250 400	FD896M	B C D E F	120	A B C D E F	60 (1524.0) High	S	
							FD896N		208				
									240				
									380				
									480				
									575				
5	100 150	125 150	200 250	250 300	300 —	400 600	FD896R	B C D E F	120	A B C D E F	72 (1828.8) High	S ^①	
							FD896T		208				
									240				
									380				
									480				
									575				

① Full size bolt-in panel.

IT06 — Intelligent Technologies *IT*. Solid-State Reduced Voltage Starter — HMCP

The *IT*. solid-state reduced voltage starter uses SCRs when starting and a low impedance run circuit during operation. Solid-state starters have (5) 24V DC inputs and 2 relay outputs. Soft start units include a disconnect, starter, 24V DC power supply and 100VA CPT.

Motor Service Factor (SF) Effect on *IT*. Starter Selection

- A 1.0 service factor motor may draw up to 1.00 x full load amperes.
- A 1.15 service factor motor may draw up to 1.15 x full load amperes.
- 15% more current. *IT*. starters are current rated devices. In some cases, a larger *IT*. SSRV starter must be supplied for 1.15 SF motors. See the maximum horsepower chart below.

Note: Most motors used in industrial applications are 1.15 Service Factor (SF).

Table 13. Replacement *IT*. Soft Start Units

Service Factor	Horsepower	<i>IT</i> . Soft-Start Amperes	HMCP Amperes	Catalog Code	Service Voltage	Catalog Code	Control Voltage	Catalog Code	Space Options Inches (mm)	Catalog Code	
1.15	20	37	150	FD306A	480	E	120	A	18 (457.2) High	S	
	40	66		FD306B				B			
	60	105	250	FD306C				C			36 (914.4) High
	75	135		FD306D				D			
	125	180	400 ^②	FD306E				E			
	150	240		FD306F				F			
	200	304		FD306G				—			
	—	—		—				—			

② No stab — unit cable-in/cable-out.

Table 14. Adjustable Frequency Drive Units

Consult Factory for Price and Availability

Freedom Unitrol Replacement Starter Units

Table 15. Full Voltage Non-Reversing — Fusible ①

NEMA Size	Maximum Horsepower					Fuse Clip Amperes	Catalog Code	Service Voltage	Catalog Code	Control Voltage	Catalog Code	Space Options Inches (mm)	Catalog Code
	208V	240V	380V	480V	600V								
1	7.5	7.5	10	10	10	30	FD204C	208 240 380 480 575	B C D E F	120 208 240 380 480 575	A B C D E F	6 (152.4) High 12 (304.8) High 18 (457.2) High	C ②③ S X
2	— 10	— 15	15 25	15 25	25 —	30 60	FD204E FD204F	208 240 380 480 575	B C D E F	120 208 240 380 480 575	A B C D E F	12 (304.8) High 18 (457.2) High	S X
3	— 25	20 30	30 50	40 50	50 —	60 100	FD204H FD204J	208 240 380 480 575	B C D E F	120 208 240 380 480 575	A B C D E F	24 (609.6) High	S
4	— 50	— 50	— 50	60 100	75 100	100 200	FD204L FD204M	208 240 380 480 575	B C D E F	120 208 240 380 480 575	A B C D E F	36 (914.4) High	S
5	60	60	100	150	150	200	FD204P	208 240 380 480 575	B C D E F	120 208 240 380 480	A B C D E	60 (1524.0) High	C ④
	100	100	150	200	200	400	FD204R					72 (1828.8) High	S ⑤

① Fuse clip ratings shown are based on Class RK1, 5 fuses for all units except 6-inch (152.4 mm) units which use CC fuses.

② Available in Class J only.

③ On 6-inch (152.4 mm) units, the only options available are (3) E22 pilot devices and separate source fuse or disconnect or CPT.

④ Available in Class J and Form IIC fuses.

⑤ Full size bolt-in panel.

Table 16. Full Voltage Reversing — Fusible ⑥

NEMA Size	Maximum Horsepower					Fuse Clip Amperes	Catalog Code	Service Voltage	Catalog Code	Control Voltage	Catalog Code	Space Options Inches (mm)	Catalog Code
	208V	240V	380V	480V	600V								
1	7.5	7.5	10	10	10	30	FD214C	208 240 380 480 575	B C D E F	120 208 240 380 480 575	A B C D E F	18 (457.2) High 24 (609.6) High	C S
2	— 10	— 15	15 25	15 25	25 —	30 60	FD214E FD214F	208 240 380 480 575	B C D E F	120 208 240 380 480 575	A B C D E F	18 (457.2) High 24 (609.6) High	C S
3	— 25	20 30	30 50	40 50	50 —	60 100	FD214H FD214J	208 240 380 480 575	B C D E F	120 208 240 380 480 575	A B C D E F	36 (914.4) High	S
4	— 50	— 50	— 60	60 100	75 100	100 200	FD214L FD214M	208 240 380 480 575	B C D E F	120 208 240 380 480 575	A B C D E F	48 (1219.2) High	S

⑥ Fuse clip ratings shown are based on Class RK1, 5 fuses for all units except 6-inch (152.4 mm) units which use CC fuses.

Freedom Unitrol Replacement Starter Units

Table 17. Full Voltage 2 Speed 1 Winding — Fusible — Constant/Variable Torque ①②

NEMA Size	Maximum Horsepower					Fuse Clip Amperes	Catalog Code	Service Voltage	Catalog Code	Control Voltage	Catalog Code	Space Options Inches (mm)	Catalog Code
	208V	240V	380V	480V	600V								
1	7.5	7.5	10	10	10	30	FD944C	208 240 380 480 575	B C D E F	120 208 240 380 480 575	A B C D E F	24 (609.6) High 36 (914.4) High	C S
2	— 10	— 15	15 25	15 25	25 —	30 60	FD944E FD944F	208 240 380 480 575	B C D E F	120 208 240 380 480 575	A B C D E F	24 (609.6) High 36 (914.4) High	C S
3	— 25	20 30	30 50	40 50	50 —	60 100	FD944H FD944J	208 240 380 480 575	B C D E F	120 208 240 380 480 575	A B C D E F	48 (1219.2) High	S
4	— 50	— 50	— 60	60 100	75 100	100 200	FD944L FD944M	208 240 380 480 575	B C D E F	120 208 240 380 480 575	A B C D E F	60 (1524.0) High	S

① Fuse clip ratings shown are based on Class RK1, 5 fuses for all units except 6-inch (152.4 mm) units which use CC fuses.

② For constant horsepower instead of constant/variable torque, see Option SV6 on Page 17.

Table 18. Full Voltage 2 Speed 2 Winding — Fusible — Constant/Variable Torque ③④

NEMA Size	Maximum Horsepower					Fuse Clip Amperes	Catalog Code	Service Voltage	Catalog Code	Control Voltage	Catalog Code	Space Options Inches (mm)	Catalog Code
	208V	240V	380V	480V	600V								
1	7.5	7.5	10	10	10	30	FD954C	208 240 380 480 575	B C D E F	120 208 240 380 480 575	A B C D E F	24 (609.6) High 30 (762.0) High	C S
2	— 15	— 15	15 25	15 25	25 —	30 60	FD954E FZ954F	208 240 380 480 575	B C D E F	120 208 240 380 480 575	A B C D E F	24 (609.6) High 30 (762.0) High	C S
3	— 25	20 30	30 50	40 50	50 —	60 100	FD954H FD954J	208 240 380 480 575	B C D E F	120 208 240 380 480 575	A B C D E F	48 (1219.2) High	S
4	— 50	— 50	— 60	60 100	75 100	100 200	FD954L FD954M	208 240 380 480 575	B C D E F	120 208 240 380 480 575	A B C D E F	60 (1524.0) High	S

③ Fuse clip ratings shown are based on Class RK1, 5 fuses for all units except 6-inch (152.4 mm) units which use CC fuses.

④ For constant horsepower instead of constant/variable torque, see option SV6 on Page 17.

Freedom Unitrol Replacement Starter Units

Table 19. Reduced Autotransformer — Fusible ①

NEMA Size	Maximum Horsepower					Fuse Clip Amperes	Catalog Code	Service Voltage	Catalog Code	Control Voltage	Catalog Code	Space Options Inches (mm)	Catalog Code
	208V	240V	380V	480V	600V								
2	—	—	15	15	25	30 60	FD604E FD604F	208 240 380 480 575	B C D E F	120 208 240 380 480 575	A B C D E F	48 (1219.2) High	S
	10	15	25	25	—								
3	—	20	30	40	50	60 100	FD604H FD604J	208 240 380 480 575	B C D E F	120 208 240 380 480 575	A B C D E F	60 (1524.0) High	S
	25	30	50	50	—								
4	—	—	—	60	75	100 200	FD604L FD604M	208 240 380 480 575	B C D E F	120 208 240 380 480 575	A B C D E F	72 (1828.8) High	S ②
	50	50	60	100	100								

① Fuse clip ratings shown are based on Class RK1, 5 fuses for all units except 6-inch (152.4 mm) units which use CC fuses.

② If existing MCC is back-to-back design, 36 inches (914.4 mm) in bottom rear is unusable.

Table 20. Reduced Voltage Part Winding — Fusible ③

NEMA Size	Maximum Horsepower					Fuse Clip Amperes	Catalog Code	Service Voltage	Catalog Code	Control Voltage	Catalog Code	Space Options Inches (mm)	Catalog Code
	208V	240V	380V	480V	600V								
1	10	10	15	15	15	60	FD704D	208 240 380 480 575	B C D E F	120 208 240 380 480 575	A B C D E F	24 (609.6) High	S
2	—	15	25	30	40	60	FD704F	208 240 380 480 575	B C D E F	120 208 240 380 480 575	A B C D E F	24 (609.6) High	S
	20	25	40	40	—	100	FD704G	208 240 380 480 575	B C D E F	120 208 240 380 480 575	A B C D E F	30 (762.0) High	S
3	—	—	—	50	60	100	FD704J	208 240 380 480 575	B C D E F	120 208 240 380 480 575	A B C D E F	36 (914.4) High	S
	40	50	75	75	75	200	FD704K	208 240 380 480 575	B C D E F	120 208 240 380 480 575	A B C D E F	48 (1219.2) High	S
4	50	—	100	100	150	200	FD704M	208 240 380 480 575	B C D E F	120 208 240 380 480 575	A B C D E F	48 (1219.2) High	S
	75	75	150	150	—	400	FD704N	208 240 380 480 575	B C D E F	120 208 240 380 480 575	A B C D E F	60 (1524.0) High	S ④

③ Fuse clip ratings shown are based on Class RK1, 5 fuses for all units except 6-inch (152.4 mm) units which use CC fuses.

④ Full size bolt-in panel.

Freedom Unitrol Replacement Starter Units

Table 21. Reduced Voltage Wye Delta Open Transition — Fusible ①

NEMA Size	Maximum Horsepower					Fuse Clip Amperes	Catalog Code	Service Voltage	Catalog Code	Control Voltage	Catalog Code	Space Options Inches (mm)	Catalog Code
	208V	240V	380V	480V	600V								
2	15	15	30	40	40	60	FD804F	208	B C D E F	120	A B C D E F	30 (762.0) High	S
	20	25	40	—	—	100	FD804G	240 208 380 480 575		208 240 380 480 575		36 (914.4) High	S
3	25	30	50	60	75	100	FD804J	208	B C D E F	120	A B C D E F	36 (914.4) High	S
	40	50	75	75	—	200	FD804K	240 208 380 480 575		208 240 380 480 575		48 (1219.2) High	S
4	50	60	100	125	150	200	FD804M	208	B C D E F	120	A B C D E F	48 (1219.2) High	S
	60	75	150	150	—	400	FD804N	240 208 380 480 575		208 240 380 480 575		72 (1828.8) High	S ^②
5	100	125	200	250	300	400	FD804R	208	B C D E F	120	A B C D E F	48 (1219.2) High	S
	150	150	250	300	—	600	FD804T	240 208 380 480 575		208 240 380 480 575		72 (1828.8) High	S ^②

① Fuse clip ratings shown are based on Class RK1, 5 fuses for all units except 6-inch (152.4 mm) units which use CC fuses.

② Full size bolt-in panel.

Table 22. Reduced Voltage Wye Delta Closed Transition ③

NEMA Size	Maximum Horsepower					Fuse Clip Amperes	Catalog Code	Service Voltage	Catalog Code	Control Voltage	Catalog Code	Space Options Inches (mm)	Catalog Code
	208V	240V	380V	480V	600V								
2	15	15	30	40	40	60	FD894F	208	B C D E F	120	A B C D E F	30 (762.0) High	S
	20	25	40	—	—	100	FD894G	240 208 380 480 575		208 240 380 480 575		36 (914.4) High	S
3	25	30	50	60	75	100	FD894J	208	B C D E F	120	A B C D E F	48 (1219.2) High	S
	40	50	75	75	—	200	FD894K	240 208 380 480 575		208 240 380 480 575			
4	50	60	100	125	150	200	FD894M	208	B C D E F	120	A B C D E F	60 (1524.0) High	S
	60	75	150	150	—	400	FD894N	240 208 380 480 575		208 240 380 480 575		72 (1828.8) High	S ^④

③ Fuse clip ratings shown are based on Class RK1, 5 fuses for all units except 6-inch (152.4 mm) units which use CC fuses.

④ Full size bolt-in panel.

Freedom Unitrol Unit Options

Table 23. Option Groups ①

Groups	Description	Page Number
A	Advantage Options	15
B	Circuit Breaker Options	15
C	Control Power Source Options	15
G	Ground Fault Protection Options	15
M	Metering Options	16
O	Overload Options	16
P	Pilot Device Options	16
R	Relay and Timer (Control, Voltage, Current) Options	17
S	Starter Contact Options	17
SV	Vacuum Starter Options	17
T	Terminal Block Options	17
U	Unit Wiring Options	17

① Select your option suffix and attach it to the end of the catalog number.

Table 24. Option Suffix

Suffix	Description	Space Required ②
--------	-------------	------------------

A — Advantage Options

A10	Substitute Advantage Starter Size 1	③
A11	Substitute Advantage Starter Size 2	③
A12	Substitute Advantage Starter Size 3	③
A13	Substitute Advantage Starter Size 4	③
A14	Substitute Advantage Starter Size 5	C ③④
A15	Advantage Hand/Off/Auto ACM for FVNR or RVNR Starters	C ④
A16	Advantage Stop/Start for FVNR or RVNR Starters	C ④
A17	Advantage Hand/Off/Auto-Start/Stop ACM for FVNR or RVNR Starters	C ④
A18	Advantage Fast/Slow/Stop 2-Speed Starters	C ④
A19	Advantage Forward/Reverse/Stop for Reversing Starters	C ④
A20	Advantage Fast/Slow/Off/Auto for 2-Speed Starters	C ④
A21	Advantage Forward/Reverse/Off/Auto for Reversing Starters	C ④
A22	ACM Metering Module	C ④
A23	WBELL Form C Bell Alarm Contact	C ④
A24	Reset with Overload Alarm and Trip Indication	C ④
A25	120V AC PLC Circuit Compatible Load Resistor	C ④
A26	WPONI PowerNet Communications Module	C ④
A27	Advantage Status Only ACM	C ④
A28	WPONIDNA DeviceNet Communications Module	C ④

B — Breaker Options

B10	Shunt Trip 120V AC Wired to Terminal Blocks for Remote Tripping	C
B11	Auxiliary Switch Form C (1NO/1NC) Wired to Terminal Blocks	C
B12	Form C Bell Alarm Contact (1NO/1NC) Wired to Terminal Blocks	C
B13	Undervoltage Release	C
B14	IQ Energy Sentinel — F Frame	③
B15	IQ Energy Sentinel — J Frame	③
B16	IQ Energy Sentinel — K Frame	③
B17	IQ Central Energy Display	③
B18	Thermal Magnetic Circuit Breaker Instead of HMCP	—

C — Control Power Source Options

C10	Control Fuse Wired for Separate Source in Lieu of Control Power Transformer	C
C11	Control Fuse with Disconnect for Separate Source in Lieu of Control Power Transformer	C
C12	Control Power Transformer 100 VA for Size 1 and 2 Starters (Fused)	C ④
C13	Control Power Transformer 150 VA for Size 3 and 4 Starters (Fused)	C
C14	Control Power Transformer 100 VA with Interposing Relay for Size 5 Starters, Fused	C
C15	Extra 50 VA for Control Power Transformer	S
C16	Extra 100 VA for Control Power Transformer	S
C17	Service Voltage Control, Fused in Lieu of Control Power Transformer	C
C18	Full Capacity Control Power Transformer for Size 5 Starters, Fused	C

G — Ground Fault Protection Options

G10	Class 1 Ground Fault Protection — GRT1 Size 1 – 4	X
G11	Class 1 Ground Protection — GRT1 Size 5 – 6	X
G12	Ground Fault Test Panel	X

② Minimum unit size required (refer to Replacement Unit pages).

③ Consult factory for spacing.

④ Not available in 6 inches (152.4 mm).

Freedom Unitrol Unit Options

Table 24. Option Suffix (Continued)

Suffix	Description	Space Required ^①
M — Metering Options		
M10	Mini Voltmeter	C ^②
M11	Mini Ammeter with Current Transformer	S
M12	Mini Elapsed Time Meter	C ^②
M13	Current Transformer for Remote Metering	S
M14	Current Transducer 4-20 mA Output	X
O — Overload Options		
O10	IQ 500 Solid-State Overload Relay	—
O11	IQ 500 Load Protection Module	—
O16	Bell Alarm (1NO) Wired	C
O17	Bi-Metallic Overload Substitution	C
O18	Adjustable A200 Overload Substitution	C
O19	Overload Relay Heater/Heater Pack	C
O20	CEP7 Solid-State Overload Relay	C
P — Pilot Device Options ^③		
P10	Red "RUN" Light	C
P11	Green "STOPPED" Light	C
P12	Amber "OVERLOAD TRIPPED" Light	C
P13	Green "RUN" Light	C
P14	Red "STOPPED" Light	C
P15	Red "RUN" Push-to-Test Light	C
P16	Green "STOPPED" Push-to-Test Light	C
P17	Amber "OVERLOAD TRIPPED" Push-to-Test Light	C
P18	Green "RUN" Push-to-Test Light	C
P19	Red "STOPPED" Push-to-Test Light	C
P20	Special Function Light	C
P30	"START" Pushbutton	C
P31	"STOP" Pushbutton	C
P32	"START/STOP" Pushbutton	C
P33	"ON" Pushbutton	C
P34	"OFF" Pushbutton	C
P35	"ON/OFF" Pushbutton	C
P36	"FORWARD/REVERSE/STOP" Pushbutton	C
P37	"FAST/SLOW/STOP" Pushbutton	C
P38	"FAST/OFF/SLOW" Pushbutton	C
P39	"HIGH/LOW/STOP" Pushbutton	C
P40	"HIGH/LOW/OFF" Pushbutton	C
P41	Special Function Pushbutton	C
P50	"ON-OFF" Selector Switch	C
P51	"HIGH-LOW" Selector Switch	C
P52	"OFF-AUTO" Selector Switch	C
P53	"START-STOP" Selector Switch	C
P54	"SLOW-FAST" Selector Switch	C
P55	"FORWARD-REVERSE" Selector Switch	C
P56	Special Function 2-Position Selector Switch	C
P57	"HAND-OFF-AUTO" Selector Switch	C
P58	"LOCAL-OFF-REMOTE" Selector Switch	C
P59	"FAST-OFF-SLOW" Selector Switch	C
P60	"HIGH-OFF-LOW" Selector Switch	C
P61	Special Function 3-Position Selector Switch	C
P62	"HIGH-LOW-OFF-AUTO" Selector Switch	C
P63	Special Function 4-Position Selector Switch	C

① Minimum unit size required (refer to Replacement Unit pages).

② Customer to supply range of meter required.

③ Available only with F2100, Advantage, Series 2100/5 Star, Freedom Unitrol, F10 Unitrol and Type W. Consult factory for specific size limitations.

Freedom Unitrol Unit Options

Table 24. Option Suffix (Continued)

Suffix	Description	Space Required ^①						
R — Relay and Timer Options								
R10	Auxiliary Control Relay 2-Pole (1NO/1NC) Convertible Contacts Wired in Parallel with Starter Coil	S						
R11	Auxiliary Control Relay 4-Pole (2NO/2NC) Convertible Contacts Wired in Parallel with Starter Coil	S						
R12	Auxiliary Control Relay 2-Pole Overload Alarm (1NO/1NC) Convertible Contacts	S						
R13	Mechanical Latching Relay (Specify Connection)	X						
R14	Ice Cube Relay 300 Volts 3-Pole Blade Type (Specify Connection)	S						
R15	Phase Voltage Relay	X						
R16	Current Sensing Relay with Contacts Wired to Terminal Blocks	X						
R17	Deceleration Timing Relay (Pneumatic "OFF" Delay)	S						
R18	Compelling Timer (Pneumatic "ON" Delay)	S						
R19	Time Clock 24 Hour	②						
R20	Time Clock 7 Day	②						
R21	Solid-State Timer Type TR (Specify Connection)	S						
R22	DN65 DeviceNet Interface Module	S						
R23	D Series Relay (Number of Poles Must be Specified)	C						
S — Starter Contact Options (Maximum of 8 Contacts)								
S__	To order extra starter contacts, you must specify the number of NO/NC contacts, given a maximum of eight (8). To define the unit option required, create a suffix based on the following example:							
	<table border="1" style="margin-left: auto; margin-right: auto;"> <thead> <tr> <th></th> <th>Quantity of Normally Open Contacts</th> <th>Quantity of Normally Closed Contacts</th> </tr> </thead> <tbody> <tr> <td>S</td> <td>2</td> <td>3</td> </tr> </tbody> </table>		Quantity of Normally Open Contacts	Quantity of Normally Closed Contacts	S	2	3	
	Quantity of Normally Open Contacts	Quantity of Normally Closed Contacts						
S	2	3						
SV — Vacuum Starter Options								
SV4	Vacuum Starter Size 4 Substitution FVNR (Consult Factory for Spacing)	—						
SV5	Vacuum Starter Size 5 Substitution FVNR (Consult Factory for Spacing)	—						
SV6	Constant Horsepower Instead of Constant/Variable Torque	—						
T — Terminal Block Options								
T10	Pull-apart Type (Standard on all Vintages Except Type W and 11-300)	S						
T11	Utility Screw Type (Add 6 Inches (152.4 mm) for Every 18 Points)	—						
T12	Front-Mounted Pull-apart Type for Freedom 2100, Advantage, Series 2100/5 Star	S						
U — Unit Wiring Options								
U10	Surge Suppressor on Coil	C						
U11	Type SIS Control Wire	C						
U12	Type SIS Power Wire	C						
U13	Type 14 Gauge Control Wire (Standard for all Vintages Except F2100, Series 2100/5 Star, Type W and 11-300)	C						
U14	Wiremarkers Sleeve Type on all Control Wire	C						
U15	Locking Fork Terminals on all Control Wiring	S						
U16	Ring Wire Terminals on Power Wiring	S						
U17	Wiring Diagram Inside Starter Unit Door	C						
U18	Ring Tongue Lugs on Control Wire	C						

① Minimum unit size required (refer to Replacement Unit pages).

② Consult factory for spacing.

Freedom Unitrol Structure Parts

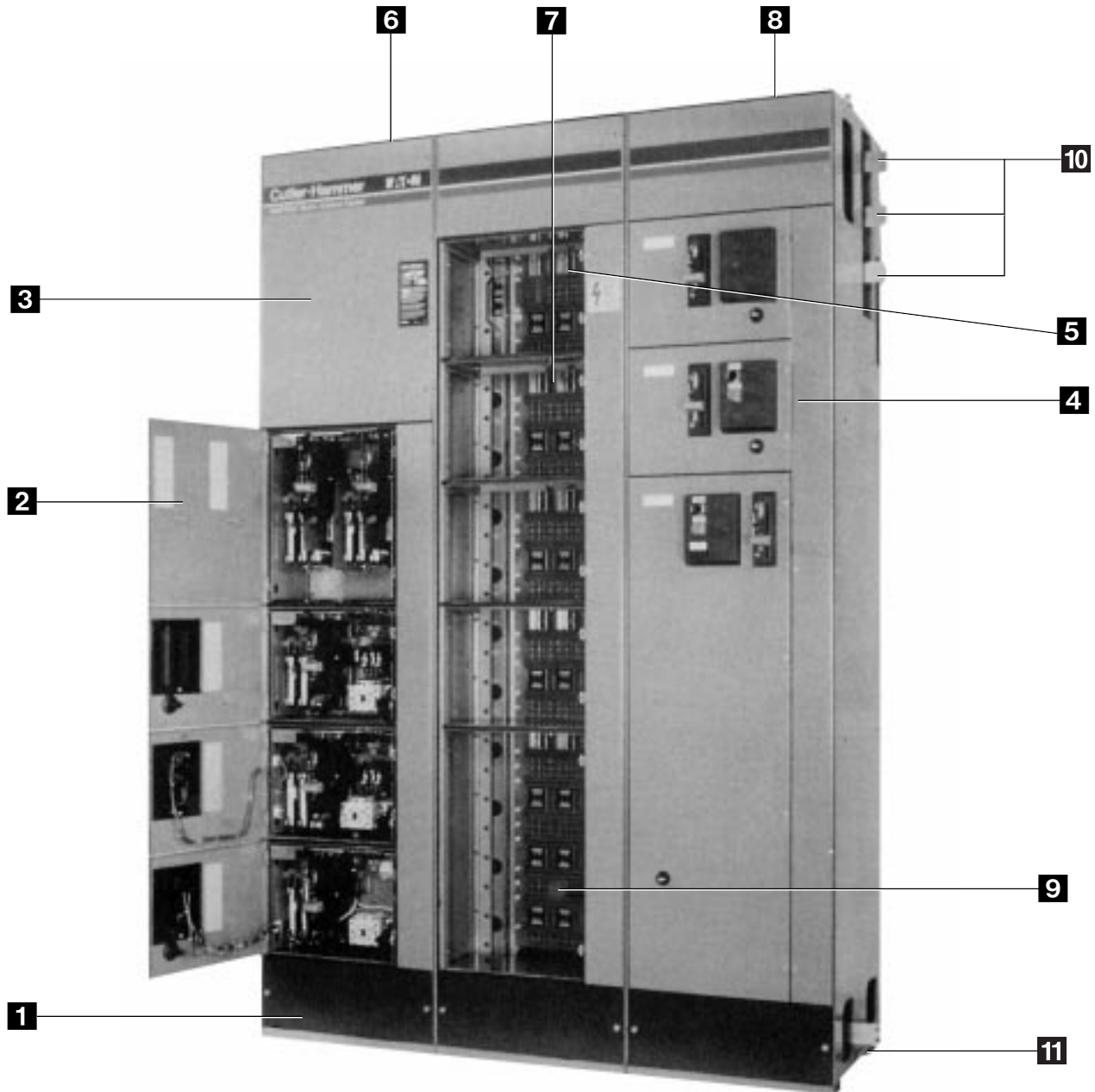

Table 25. Structure Parts

Reference	Description	Page
1	Bottom Front Plate with Mounting Hardware	19
2	Door Mounting Hardware Kit	19
3	Blank Unit Door	19
4	Vertical Wireway Door	19
5	Stab-in Opening Cover	19
6	Top Front Plate with Mounting Hardware	20

Reference	Description	Page
7	Unit Support Tray	20
8	Horizontal to Vertical Bus Bar Connector Kit Roof Plate	20 20
9	Vertical Bus Labyrinth Vertical Bus Bar	20 20
10	Main Horizontal Bus	21
11	Horizontal Ground Bus Horizontal Ground Bus Mounting Hardware Kit Horizontal Bus Mounting Hardware Tophats	22 22 22 22

**Freedom Unitrol
Structure Parts**

**Bottom Front Plate with Mounting
Hardware 1**

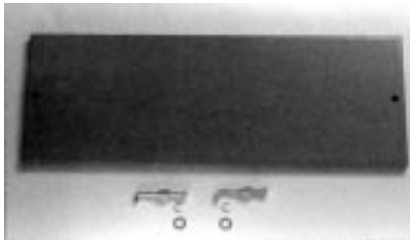

Bottom Front Plate with Mounting Hardware

Table 26. Bottom Front Plate with Mounting Hardware

Dimensions in Inches (mm)		Style Number
Height	Width	
8 (203.2)	20 (508.0)	47-28140
8 (203.2)	30 (762.0)	47-28140-2
8 (203.2)	40 (1016.0)	47-32387-2

Door Mounting Hardware Kit 2



Door Mounting Hardware Kit

Table 27. Door Mounting Hardware Kit

Description	Style Number
Kit includes 2 hinges with hinge pins, (2) 1/4 turn latches, and label.	3A73617G01

Blank Unit Door 3

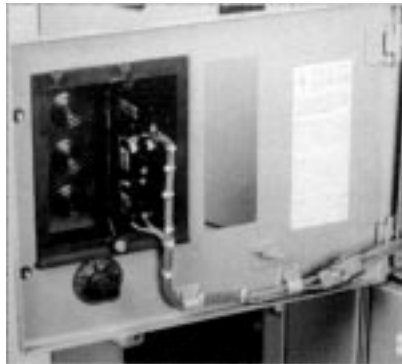

Blank Unit Door

Table 28. Blank Unit Door

Dimensions in Inches (mm)		Style Number
Height	Width	
6 (152.4)	15 (381.0)	47-28134-2
12 (304.8)	15 (381.0)	47-28111-2
18 (457.2)	15 (381.0)	47-28112-2
24 (609.6)	15 (381.0)	47-28113-2
30 (762.0)	15 (381.0)	47-28114-2
36 (914.4)	15 (381.0)	47-28115-2
48 (1219.2)	15 (381.0)	47-28117-2
60 (1524.0)	15 (381.0)	47-28119-2
72 (1828.8)	20 (508.0)	47-28110-2

Vertical Wireway Door 4



Vertical Wireway Door

Table 29. Vertical Wireway Door

Door Height in Inches (mm)	Style Number
24 (609.6)	47-28133-5
30 (762.0)	47-28133-7
36 (914.4)	47-28133-9
48 (1219.2)	47-28133-13
54 (1371.6)	47-28133-15
60 (1524.0)	47-28133-17
72 (1828.8)	47-28133-21

Stab-in Opening Cover 5



Stab-in Opening Cover

Table 30. Stab-in Opening Cover

Description	Style Number
Stab-in Opening Cover	49-5845

Freedom Unitrol Structure Parts

Top Front Plate with Mounting Hardware 6

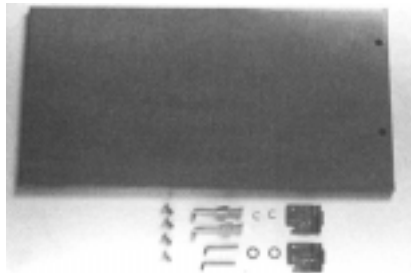

Top Front Plate with Mounting Hardware

Table 31. Top Front Plate with Mounting Hardware

Dimensions in Inches (mm)		Style Number
Height	Width	
10 (254.0)	20 (508.0)	47-32386-2
10 (254.0)	30 (762.0)	47-32386-4
22 (558.8)	20 (508.0)	47-28139-2
28 (711.2)	20 (508.0)	47-32884-2
34 (863.6)	20 (508.0)	47-32885-2

Unit Support Tray 7

Table 32. Unit Support Tray

Description	Style Number
Standard Tray	73-2573
Tray with Cable Openings	73-2573-2

Horizontal to Vertical Bus Bar Connector Kit 8



Horizontal to Vertical Bus Bar Connector Kit

Table 33. Horizontal to Vertical Bus Bar Connector Kit

Description	Style Number
Horizontal to Vertical Bus Bar Connector Kit	3A73617G02

For each phase of a 3-phase system, the kit includes 4 each of the following:

- Vertical screws.
- Vertical lock washers.
- Vertical flat washers.

and, 2 each of the following:

- Single horizontal screws.
- Parallel horizontal screws.
- Horizontal flat washers.
- Horizontal lock washers.

Roof Plate 8

Table 34. Roof Plate

Dimensions in Inches (mm)		Style Number
Width	Depth	
Roof Plate		
20 (508.0)	15 (381.0)	47-32268
20 (508.0)	20 (508.0)	47-32270
30 (762.0)	15 (381.0)	47-32269
30 (762.0)	20 (508.0)	47-32271
40 (1016.0)	20 (508.0)	47-32383

Roof Plate with Tophat Cutout

20 (508.0)	15 (381.0)	47-32268-2
20 (508.0)	20 (508.0)	47-32270-2
30 (762.0)	15 (381.0)	47-32269-2
30 (762.0)	20 (508.0)	47-32271-2
40 (1016.0)	20 (508.0)	47-32383-2

Vertical Bus Labyrinth 9

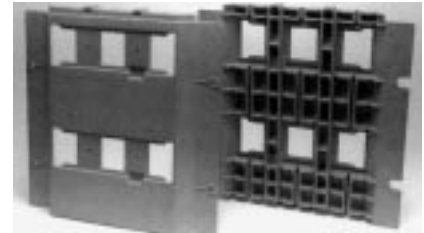

Vertical Bus Labyrinth

Table 35. Vertical Bus Labyrinth ①

Description	Style Number
65 kAIC	
Front Mounted	3A73617G03
Back-to-Back Mountings	3A73617G04
100 kAIC	
Front Mounted	3A73617G05
Back-to-Back Mountings	3A73617G06

① Barrier shipped with hardware and enough bus sections to assemble a 72-inch (1828.8 mm) labyrinth.

Vertical Bus Bar 9

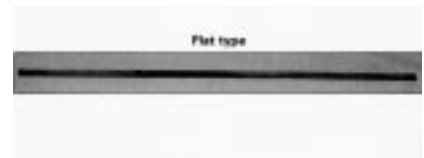

Vertical Bus Bar

Table 36. Vertical Bus Bar

Flat Type			Style Number
Amperes	Phase	kAIC	
400	A	65	25-6608-9
400	B	65	25-6608-10
400	C	65	25-6608-11
400	A	100	25-6608-15
400	B	100	25-6608-16
400	C	100	25-6608-17

**Freedom Unitrol
Structure Parts**

Main Horizontal Bus 10



Main Horizontal Bus

Table 37. Main Horizontal Bus

Bus		Phase	Sections		Style Number		
Amperes	Size in Inches (mm)		Number	Width in Inches (mm)			
800	.25 (6.4) x 2 (50.8)	A	1	20 (508.0)	25-6586-2		
		A	1	30 (762.0)	25-6596-4		
		A	2	40 (1016.0)	25-6587-2		
		A	3	60 (1524.0)	25-6588-2		
		B	1	20 (508.0)	25-6586-3		
		B	1	30 (762.0)	25-6596-6		
		B	2	40 (1016.0)	25-6587-3		
		B	3	60 (1524.0)	25-6588-3		
		C	1	20 (508.0)	25-6586-4		
		C	1	30 (762.0)	25-6596-8		
		C	2	40 (1016.0)	25-6587-4		
		C	3	60 (1524.0)	25-6588-4		
		1000	.25 (6.4) x 3 (76.2)	A	1	20 (508.0)	25-6589-2
				A	1	30 (762.0)	25-6597-4
A	2			40 (1016.0)	25-6590-2		
A	3			60 (1524.0)	25-6591-2		
B	1			20 (508.0)	25-6589-3		
B	1			30 (762.0)	25-6597-6		
B	2			40 (1016.0)	25-6590-3		
B	3			60 (1524.0)	25-6591-3		
C	1			20 (508.0)	25-6589-4		
C	1			30 (762.0)	25-6597-8		
C	2			40 (1016.0)	25-6590-4		
C	3			60 (1524.0)	25-6591-4		
1200	.25 (6.4) x 4 (101.6)			A	1	20 (508.0)	25-6592-2
				A	1	30 (762.0)	25-6598-4
		A	2	40 (1016.0)	25-6593-2		
		A	3	60 (1524.0)	25-6594-2		
		B	1	20 (508.0)	25-6592-3		
		B	1	30 (762.0)	25-6598-6		
		B	2	40 (1016.0)	25-6593-3		
		B	3	60 (1524.0)	25-6594-3		
		C	1	20 (508.0)	25-6592-4		
		C	1	30 (762.0)	25-6598-8		
		C	2	40 (1016.0)	25-6593-4		
		C	3	60 (1524.0)	25-6594-4		
		1600 ①	(2) .25 (6.4) x 3 (76.2)	A	1	20 (508.0)	25-6589-2
				A	1	30 (762.0)	25-6597-4
A	2			40 (1016.0)	25-6590-2		
A	3			60 (1524.0)	25-6591-2		
B	1			20 (508.0)	25-6589-3		
B	1			30 (762.0)	25-6597-6		
B	2			40 (1016.0)	25-6590-3		
B	3			60 (1524.0)	25-6591-3		
C	1			20 (508.0)	25-6589-4		
C	1			30 (762.0)	25-6597-8		
C	2			40 (1016.0)	25-6590-4		
C	3			60 (1524.0)	25-6591-4		
2000 ①	(2) .25 (6.4) x 4 (101.6)			A	1	20 (508.0)	25-6592-2
				A	1	30 (762.0)	25-6598-4
		A	2	40 (1016.0)	25-6593-2		
		A	3	60 (1524.0)	25-6594-2		
		B	1	20 (508.0)	25-6592-3		
		B	1	30 (762.0)	25-6598-6		
		B	2	40 (1016.0)	25-6593-3		
		B	3	60 (1524.0)	25-6594-3		
		C	1	20 (508.0)	25-6592-4		
		C	1	30 (762.0)	25-6598-8		
		C	2	40 (1016.0)	25-6593-4		
		C	3	60 (1524.0)	25-6594-4		

① For 1600 amperes and 2000 amperes main horizontal bus applications, order a quantity of two (2) of the specific style number selected.

**Freedom Unitrol
Structure Parts**

Horizontal Ground Bus 



Horizontal Ground Bus

Table 38. Horizontal Ground Bus

Description		Style Number
Sections	Width in Inches (mm)	
1	20 (508.0)	25-6586-10
1	30 (762.0)	25-6596-18
1	40 (1016.0)	25-6587-10
2	40 (1016.0)	25-6587-10
3	60 (1524.0)	25-6588-10

**Horizontal Ground Bus
Mounting Hardware Kit** 

Table 39. Horizontal Ground Bus Mounting Hardware Kit

Description	Style Number
Kit includes 2 mounting brackets per section, 2 mounting bolts, 2 flat washers, 2 lock washers, 2 nuts and 4 bracket screws.	3A73617G07

**Horizontal Bus
Mounting Hardware** 

Table 40. Horizontal Bus Mounting Hardware

Ampere	Description	Style Number
800 1000 1200	2 each of the following: bolt, flat washer, lock washer, nut.	3A73617G08
1600 2000	2 each of the following: bolt, flat washer, lock washer, nut.	3A73617G09

Tophats 

Table 41. Tophats

Description	Size in Inches (mm)			Style Number
	Width	Depth	Height	
2 Side Plates, Front and Back Plates, Top Plate, and 2 End Covers	20 (508.0)	15 (381.0)	12 (304.8)	3A73617G10
2 Side Plates, Front and Back Plates, Top Plate, and 2 End Covers	20 (508.0)	20 (508.0)	12 (304.8)	3A73617G11
2 Side Plates, Front and Back Plates, Top Plate, and 2 End Covers	20 (508.0)	15 (381.0)	18 (457.2)	3A73617G12
2 Side Plates, Front and Back Plates, Top Plate, and 2 End Covers	20 (508.0)	20 (508.0)	18 (457.2)	3A73617G13

Freedom Unitrol Unit Parts

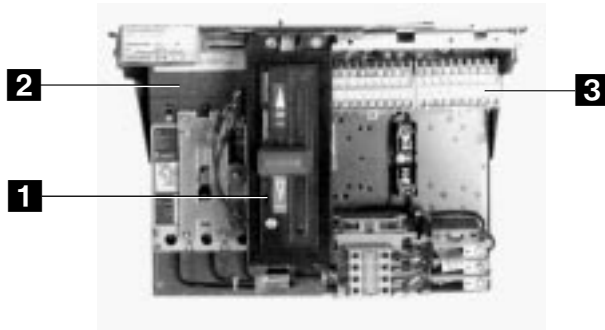

Unit — Front View

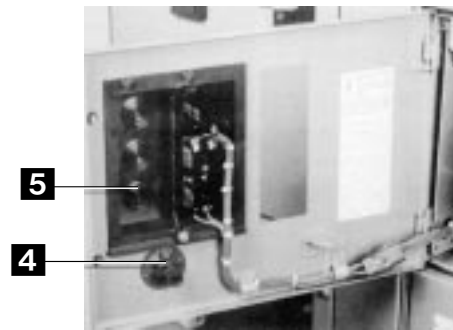

Unit Door — Rear View

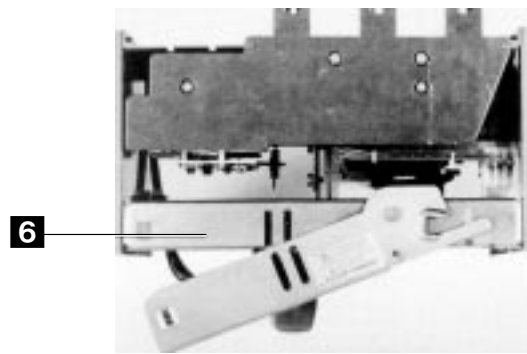

*Camming Lever, Cross Brace and
Stab Assembly — Top View*

Table 42. Unit Parts

Reference	Description	Page
1	Operating Handle Mechanism	24
	Circuit Breaker Operating Handle Mechanism	24
	Fusible Switch Operating Handle Mechanism	24
2	Line Side Shield	24
3	Terminal Blocks	25
4	Overload Reset Button	25
5	Device Panel	25

Reference	Description	Page
6	Unit Cross Brace with Latch	25
	Control Circuit Fusing	26
	Operator Interlock	26
	Transient Suppressor	26
	Replacement Autotransformers	26
	Fusible Switch Bases	26
	Unit Mounting Hardware	26

Freedom Unitrol Unit Parts

Operating Handle Mechanism 1



Operating Handle Mechanism

Table 43. Operating Handle Mechanism

Description	Style Number	Tip-in Panel
Circuit Breaker Units		
FS, FH Single	82-5821	—
FD, HFD, FDC, HMCP Single	82-6441	—
FS, FH, HMCP 6-inch (152.4 mm) Unit	82-6437	—
FS, FH, 12-inch (304.8 mm) Dual Feeder and 18-inch (457.2 mm) Starter	82-6439	—
FS, FH, 18-inch (457.2 mm) Dual Feeder	82-6440	—
FD, HFD, FDC, HMCP 12-inch (304.8 mm) Dual Feeder and 18-inch (457.2 mm) Dual Starter	82-6442	—
FD, HFD, FDC, HMCP 18-inch (457.2 mm) Dual Feeder	82-6443	—
JS, JH, JL Breaker	82-6438	—
JD, HJD, JDC, HMCP Breaker	82-6444	82-6448
KS, KH, KD, HKD, KDC, HMCP Breaker	82-6445	82-6450
LS, LH, LC, HLC, LCG, HLCG Breaker	82-5824	82-6451
MS, MH, MC, HMC, MCG, HMCG Breaker	82-5827	82-6452
NS, NH, NC, HNC, NCGM, HNCG Breaker	82-5828	82-6454
Fusible Switch Units		
30A and 60A Single	82-5829	—
30A and 60A Dual	82-6386	—
100A	82-5830	—
200A	82-5831	—
400A	82-6458	—
600A	82-6562	—
800A	82-6566	—
100A Main	82-6563	—
200A Main	82-6564	—
400A Main	82-6459	—
600A Main	82-6460	—
800A Main	82-6461	—

Line Side Shield 2

Table 44. Line Side Shield

Description	Style Number
Circuit Breaker Type	
150A	56-7615
250A and 400A	56-7692
600A	56-7693
800A and 1200A	56-7694
Fusible Switch Type	
30A and 60A	56-7616-2
100A	73-2756
200A	56-8032
400A and 600A	56-5646
800A	73-3048

Freedom Unitrol Unit Parts

Terminal Blocks 3

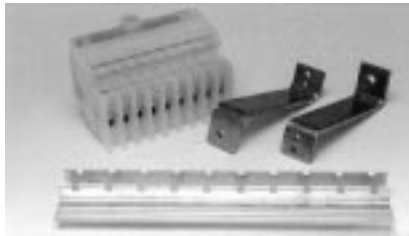

Terminal Blocks

Table 45. Terminal Blocks

Description	Style Number
3 Point with Mounting Channel	3A73617G16
9 Point with Mounting Channel	3A73617G17

Overload Reset Button and Reset Rod Extension Kit 4



Overload Reset Button and Reset Rod Extension Kit

Table 46. Overload Reset Button and Reset Rod Extension Kit ①

Description		Style Number
Size	Panel	
0 - 5	Standard	3A73617G14
6	with 8-Inch (203.2 mm) Panel Depth	
6	with Tip-in Panel	

① Kit includes button, retainer and adapter.

Device Panel 5



Device Panel

Table 47. Device Panel

Description	Style Number
Device Panel	49-6624

Cross Brace with Latch 6



Cross Brace with Latch

Table 48. Cross Brace with Latch

Description	Style Number
Cross Brace with Latch	52-2612

Freedom Unitrol Unit Parts

Control Circuit Fusing with Mounting Hardware 6

Table 49. Control Circuit Fusing with Mounting Hardware

Description	Style Number
Fuse Block 1-Pole	44-2109
Fuse Block 2-Pole	44-2104-3

Operator Interlock 6

Table 50. Operator Interlock

Description	Style Number
1NO/1NC	90-18428-2

Transient Suppressor 6

Table 51. Transient Suppressor 120V

Description	Style Number
Size 1 and 2 Suppressor	C320TS1
Size 3, 4, 5 and 6 Suppressor	C320AS1
Suppressor for D15 Relay/Timer	C320TS1
Suppressor for D26 Relay/Timer	C320MTS1

Replacement Autotransformers (480V 3-Phase) 6

Table 52. Replacement Autotransformers (480V 3-Phase)

Description	Style Number
Horsepower	
50	42-3866-30
100	42-3866-33
150	42-3866-35
200	42-3866-36
400	42-3866-39

Fusible Switch Bases 6

Table 53. Fusible Switch Bases

Description			Style Number
Amperes	Class	Volts	
30	J	600	96-2252-16
30	R	250	96-2252-15
30	R	600	96-2252-14
60	J	600	96-2252-4
60	R	250	96-2252-3
60	R	600	96-2252-2
100	J	600	96-2253-4
100	R	250	96-2253-3
100	R	600	96-2253-2
200	J	600	96-2254-4
200	R	250	96-2254-3
200	R	600	96-2254-2
400	R	250	96-2436-5
400	R	600	96-2436-12
400	J	600	96-2436-19

Unit Mounting Hardware 6

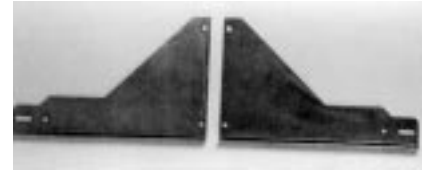

Unit Mounting Hardware

Table 54. Unit Mounting Hardware

Description	Style Number
Kit includes left and right support brackets and hardware.	3A73617G15

How to Create a Catalog Number

After selecting the circuit device required, create a Dual Mounted feeder unit catalog number based on the following:

Note: Catalog number varies in length based on single or dual mounted unit.

Table 55. Catalog Numbering System Example

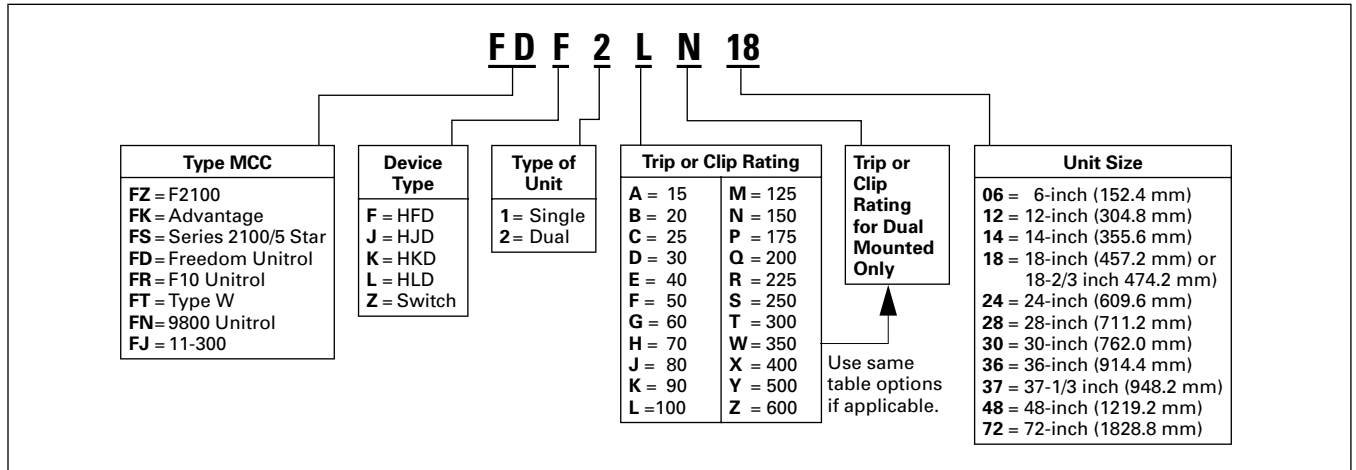

NEMA is the registered trademark and service mark of the National Electrical Manufacturers Association. UL is a registered trademark of Underwriters Laboratories Inc.

Replacement Feeder Units

Product Description

Each Feeder Unit consists of a single mounted 3-pole molded case circuit breaker or fusible switch (dual mounted are also available). Each unit includes a new wrapper, stab assembly, door, handle mechanism and customer specific disconnect device. They are shipped assembled and ready to install into the existing motor control center.

The following are simple steps to select and order a new feeder unit:

Step 1

Select the circuit device required from **Table 56** below.

Step 2

Verify the amount of space available.

Step 3

Create a catalog number from the formula in **Table 55** on **Page 27**.

Unit options and modifications for replacement feeder units:

For factory installed molded case circuit breaker modifications or additional unit options, contact the factory for prices and availability.

Table 56. Electrical Characteristics and Space Requirements of Molded Case Circuit Breaker and Fusible Switch Replacement Feeder Units — Inches (mm)

Device Type	Max. Amps	Interrupting Rating (kAIC)			Trip Rating or Clip	Freedom 2100 Series 2100/5 Star Advantage		Freedom Unitrol		F10		Type W		9800		11-300		
		240V	480V	600V		Single	Dual	Single	Dual ^①	Single	Dual ^①	Single	Dual	Single	Dual ^①	Single	Dual	
HFD	150	100	65	25	15, 20, 25, 30, 40, 50, 60, 70													
					80	6 (152.4) ^②		6 (152.4) ^②							9 (228.6)			
					90	12 (304.8) ^③	12 (304.8)	12 (304.8) ^③	12 (304.8)	12 (304.8) ^③	12 (304.8)	12 (304.8)	12 (304.8) ^③	12 (304.8)	14 (355.6)	14 (355.6)	14 (355.6)	14 (355.6)
					100													
					125	12 (304.8)	12 (304.8)	12 (304.8)	18 (457.2)	12 (304.8)	18 (457.2)	12 (304.8)	12 (304.8)	14 (355.6)	18 (457.2)	14 (355.6)	14 (355.6)	
					150	12 (304.8) ^③							12 (304.8) ^③	9 (228.6)				
HJD	250	100	65	25	175, 200													
					225	18 (457.2)		24 (609.6)		18 (457.2)		18 (457.2)		18 (457.2)		14 (355.6)		
					250													
HKD	400	100	65	35	300, 350													
					400	24 (609.6)		24 (609.6) ^④		24 (609.6) ^④		24 (609.6)		28 (711.2) ^④		14 (355.6)		
HLD	600	100	65	35	500													
					600	24 (609.6)		24 (609.6) ^④		24 (609.6) ^④								
Fusible Switch	30	100	100	100	30	12 (304.8)	12 (304.8) ^③	12 (304.8)	18 (457.2)	12 (304.8)	18 (457.2)	12 (304.8)	12 (304.8) ^③	14 (355.6)	18 (457.2)	14 (355.6)	14 (355.6)	
						60	12 (304.8)	12 (304.8) ^③	12 (304.8)	18 (457.2)	18 (457.2)	12 (304.8)	12 (304.8) ^③	14 (355.6)	18 (457.2)	14 (355.6)	14 (355.6)	
						100	18 (457.2)		18 (457.2)		18 (457.2)		12 (304.8) ^③		18 (457.2)		18 (457.2)	18-2/3 (474.2)
						200	36 (914.4)		30 (762.0)		30 (762.0)		24 (609.6)		28 (711.2)		28 (711.2)	
						400	36 (914.4)		72 (1828.8) ^④		48 (1219.2) ^④		42 (1066.8)		42 (1066.8) ^④		42 (1066.8)	
						600	48 (1219.2)		72 (1828.8) ^④									

① Combined ampacity no greater than 150A for 12-inch (304.8 mm) height. For greater than 150A, 18-inch (457.2 mm) required.

② 100A maximum.

③ Available in 18-inch (457.2 mm) height.

④ Cable in/cable out, no stab assembly.

Eaton Corporation
Cutler-Hammer business unit
1000 Cherrington Parkway
Moon Township, PA 15108-4312
USA
tel: 1-800-525-2000
www.cutler-hammer.eaton.com

